

The ASRock logo is located in the top left corner. It features the brand name 'ASRock' in a bold, green, sans-serif font. The 'A' and 'S' are connected, and the 'R' is slightly larger. A registered trademark symbol (®) is positioned at the top right of the 'k'.

ASRock®

— Industrial —

A decorative graphic on the left side of the cover consists of a cluster of triangles in various shades of green, teal, and blue. The triangles are arranged in a somewhat irregular, overlapping pattern, creating a textured, geometric effect. The colors range from light mint green to dark forest green and navy blue.

# iEP-7030E Series iEP-7031E Series

User Manual

Version 1.0

Published February 2025

Copyright©2026 ASRock Industrial. All rights reserved.

## Copyright Notice:

No part of this documentation may be reproduced, transcribed, transmitted, or translated in any language, in any form or by any means, except duplication of documentation by the purchaser for backup purpose, without written consent of ASRock Industrial Inc.

Products and corporate names appearing in this documentation may or may not be registered trademarks or copyrights of their respective companies, and are used only for identification or explanation and to the owners' benefit, without intent to infringe.

## Disclaimer:

Specifications and information contained in this documentation are furnished for informational use only and subject to change without notice, and should not be constructed as a commitment by ASRock Industrial. ASRock Industrial assumes no responsibility for any errors or omissions that may appear in this documentation.

To the extent permitted by law, with respect to the contents of this documentation, ASRock Industrial does not provide warranty of any kind, either expressed or implied, including but not limited to the implied warranties or conditions of merchantability or fitness for a particular purpose. In no event shall ASRock Industrial, its directors, officers, employees, or agents be liable for any indirect, special, incidental, or consequential damages (including damages for loss of profits, loss of business, loss of data, interruption of business and the like), even if ASRock Industrial has been advised of the possibility of such damages arising from any defect or error in the documentation or product.



This device complies with Part 15 of the FCC Rules. Operation is subject to the following two conditions:

- (1) this device may not cause harmful interference, and
- (2) this device must accept any interference received, including interference that may cause undesired operation.

## CALIFORNIA, USA ONLY

The Lithium battery adopted on this motherboard contains Perchlorate, a toxic substance controlled in Perchlorate Best Management Practices (BMP) regulations passed by the California Legislature. When you discard the Lithium battery in California, USA, please follow the related regulations in advance.

“Perchlorate Material-special handling may apply, see [www.dtsc.ca.gov/hazardouswaste/perchlorate](http://www.dtsc.ca.gov/hazardouswaste/perchlorate)”

**ASRock Industrial's Website: [www.asrockind.com](http://www.asrockind.com)**

## Important Safety Instructions

For user safety, please read and follow all instructions, Warnings, Cautions, and Notes marked in this manual and on the associated device before handling/operating the device, to avoid injury or damage.

1. Read these safety instructions carefully.
2. Retain this user manual for future reference.
3. Read the Specifications section of this manual for detailed information on the recommended operating environment.
4. Disconnect the equipment from all AC outlets before cleaning. Use only a damp cloth for cleaning. Do not use liquid or sprayed detergent.
5. Place the equipment on a reliable surface during installation. Dropping or letting the equipment fall may cause damage.
6. Do not leave the equipment in an environment with a storage temperature of below -40 °C (-40 °F) or above 85 °C (185 °F) as this may cause damage. The equipment should be stored in a controlled environment.
7. Ensure that the voltage of the power source is correct before connecting the equipment to a power outlet.
8. Position the power cord away from high-traffic areas. Do not place anything over the power cord.
9. If the equipment is not used for a long time, disconnect the equipment from the power source to avoid damage from transient over-voltage.
10. All cautions and warnings on the equipment should be noted.
11. To avoid electrical shock and/or damage to device:
  - Keep device away from water or liquid sources.
  - Keep device away from high heat or humidity.
  - Keep device properly ventilated (do not block or cover ventilation openings).
  - Always use recommended voltage and power source settings.
  - Always install and operate device near an easily accessible electrical outlet.
  - Secure the power cord (do not place any object on/over the power cord).
  - Only install/attach and operate device on stable surfaces and/or recommended mountings.
  - The power cord must be connected to a socket or outlet with a ground connection.
12. If one of the following occurs, have the equipment checked by service personnel:
  - The power cord or plug is damaged.
  - Liquid has penetrated into the equipment.
  - The equipment has been exposed to moisture.
  - The equipment is malfunctioning or does not operate according to the user manual.
  - The equipment has been dropped and damaged.

- The equipment shows obvious signs of breakage.
13. Never attempt to repair the device, which should only be serviced by qualified technical personnel using suitable tools.
  14. Any unverified component may cause unexpected damage. To ensure correct installation, always use the components (e.g., screws) provided in the accessory box.
  15. This equipment is not suitable for use in locations where children are likely to be present.
  16. The equipment should only be installed in a restricted access area.
  17. Restricted Access Location : It is recommended that the device be installed only in a server room or computer room where access is:
    - Restricted to qualified service personnel or users familiar with restrictions applied to the location, reasons therefor, and any precautions required.
    - Only afforded by the use of a tool or lock and key, or other means of security, and controlled by the authority responsible for the location.
    - Be sure to turn off the power and then disconnect the power cords from your system before performing any installation or servicing. A sudden surge of power could damage sensitive electronic components.
    - All interior servicing is to be performed by qualified skilled personnel only, which requires the use of a tool to open the metal enclosure.

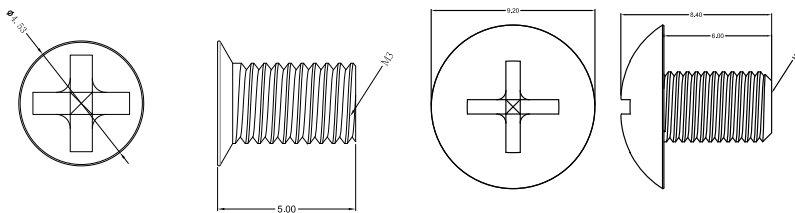

DIN Rail/Wall Mount: M3x5mm Screws (for securing the mounting bracket(s) to the chassis)

VESA Mount: M4x6mm Screws (for securing the VESA bracket to the monitor)

18. This model is intended to be supplied by an UL-certified power supply (Adapter: (1) FSP/FSP120-ABAN3, (2) FSP/FSP330-AAAN3) suitable for use at TMA 40 °C (104 °F) min., and the output is rated 19 Vdc 6.32A min., ES1. (For FSP120-ABAN3) / 24 Vdc 13.75A min., ES1 (For FSP330-AAAN). If you need further assistance, contact ASRock Industrial for additional information.
19. The terminal block is suitable for V+ & V- for 14~28AWG. The torque value is 0.19Nm. Use copper conductors only. Kindly note that this must be installed by a skilled person.

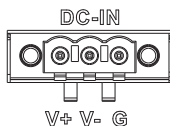

20. This product has passed the CE environmental specifications test when shielded cables are used for external connections. To comply with emission limits, shielded interface cables must be used.

## Replaceable batteries

**CAUTION : RISK OF EXPLOSION IF BATTERY IS REPLACED BY AN INCORRECT TYPE. DISPOSE OF USED BATTERIES ACCORDING TO THE INSTRUCTIONS**



## BURN HAZARD

Hot surface! Do not touch! Touching this surface could result in bodily injury. To reduce risk, allow the surface to cool before touching.

## CAUTION

The equipment is equipped with a battery-powered real-time clock circuit. There is a risk of explosion if a battery is incorrectly replaced. Replace only with same or equivalent type as recommended by the manufacturer. Discard all used batteries according to the manufacturer's instructions.

## WARNING

All interconnection to the EUT is for indoor location and therefore PoE network interconnected to the EUT is considered as ES1/SELV for connected only to PoE network without routing to the outside plant.

## WARNING

Input voltage rated 9-36V, 12.46-3.12A (For Basic SKU)

Input voltage rated 19-36V, 7.08-3.74A (For PoE SKU)

Input voltage rated 9-36V, 12.46-3.12A (For 5LAN SKU)

Input voltage rated 9-36V, 12.46-3.12A (For 5G SKU)

Input voltage rated 9-36V, 12.46-3.12A (For 8DIO SKU)

Packing: The unit should be carried with both hands and handled with care.

Maintenance: Use only approved products or a dry applicator to clean and maintain the surfaces.

## Button Battery Safety Notice

- Remove and immediately recycle or dispose of used batteries according to local regulations and keep away from children. Do NOT dispose of batteries in household trash or incinerate.
- Even used batteries may cause severe injury or death.
- Call a local poison control center for treatment information.
- Battery type: CR2032
- Battery voltage: 3V
- Non-rechargeable batteries are not to be recharged.
- Do not force discharge, recharge, disassemble, heat above (manufacturer's specified temperature rating) or incinerate. Doing so may result in injury due to venting, leakage or explosion resulting in chemical burns.
- This product contains an irreplaceable battery.
- This icon indicates that a swallowed button battery can cause serious injury or death. Please keep batteries out of sight or reach of children.



The terms HDMI® and HDMI High-Definition Multimedia Interface, and the HDMI logo are trademarks or registered trademarks of HDMI Licensing LLC in the United States and other countries.



## Contact Information

If you need to contact ASRock Industrial or want to know more about ASRock Industrial, you're welcome to visit ASRock Industrial's website at [www.asrockind.com](http://www.asrockind.com); or you may contact your dealer for further information.

### **ASRock Industrial Incorporation**

email: [Info\\_ipc@asrockind.com](mailto:Info_ipc@asrockind.com)

# Contents

<b>Chapter 1 Introduction</b>	<b>1</b>
1.1 Package Contents	1
1.2 Order Information	4
1.3 Optional Items	5
1.4 Product Specifications	6
1.4.1 System : iEP-7030E-020	6
1.4.2 System : iEP-7031E-020	7
1.4.3 System : iEP-7030E-021	8
1.4.4 System : iEP-7031E-021	9
1.4.5 System : iEP-7030E-022	10
1.4.6 System : iEP-7031E-022	11
1.4.7 System : iEP-7030E-023	12
1.4.8 System : iEP-7031E-023	13
1.4.9 System : iEP-7030E-024	14
1.4.10 System : iEP-7031E-024	15
1.4.11 System : iEP-7030E-025	16
1.4.12 System : iEP-7031E-025	17
1.5 Block Diagram	18
<b>Chapter 2 Product Overview</b>	<b>19</b>
2.1 System Front Panel	19
2.1.1 System : iEP-7030E-020, iEP-7031E-020, iEP-7030E-025, iEP-7031E-025	19

2.1.2	System : iEP-7030E-021, iEP-7031E-021, iEP-7030E-022, iEP-7031E-022, iEP-7030E-023, iEP-7031E-023, iEP-7030E-024, iEP-7031E-024	21
2.2	System Top Panel	24
2.2.1	System : iEP-7030E-020, iEP-7031E-020	24
2.2.2	System : iEP-7030E-021, iEP-7031E-021, iEP-7030E-022, iEP-7031E-022, iEP-7030E-023, iEP-7031E-023	26
2.2.3	System : iEP-7030E-024, iEP-7031E-024	28
2.2.4	System : iEP-7030E-025, iEP-7031E-025	30
2.3	Inside View	32
2.4	Rear View	33
2.5	Right View (System : iEP-7030E-020, iEP-7031E-020, iEP-7030E-025, iEP-7031E-025)	34
2.6	Position	35

## **Chapter 3 Hardware Installation 36**

3.1	How to Install the Wi-Fi Module (2230/2260) to the M.2 Key E Slot (Optional)	36
3.2	How to Install the 4G LTE/5G Module (3042/3052) to the M.2 Key B Slot (Optional)	38
3.3	How to Install the M.2 SSD (2280) to the M.2 Key M Socket	40
3.4	How to Install the Memory Modules	41
3.5	How to Install a Nano SIM Card and Micro SD Card	42
3.6	How to Install the Wall Mounting Bracket (Optional)	44
3.7	How to Install VESA Bracket (Optional) (for Basic/8DIO SKU)	46
3.8	How to Install the Din Rail (Optional)	47

3.9	How to Remove the Membranes	48
3.10	How to Install Phoenix Connector and the Adapter (Optional)	49

## **Chapter 4 Motherboard 50**

4.1	Motherboard Layout	50
4.2	Jumpers Setup	53
4.3	Onboard Headers and Connectors	55
4.4	Expansion Slots (M.2 Sockets)	58

## **Chapter 5 UEFI Setup Utility 59**

5.1	Introduction	59
5.1.1	Entering BIOS Setup	59
5.1.2	UEFI Menu Bar	60
5.1.3	Navigation Keys	61
5.2	Main Screen	62
5.3	Advanced Screen	63
5.3.1	CPU Configuration	64
5.3.2	Chipset Configuration	67
5.3.3	Storage Configuration	70
5.3.4	Super IO Configuration	72
5.3.5	AMT Configuration	74
5.3.6	ACPI Configuration	76
5.3.7	USB Configuration	77
5.3.8	Trusted Computing	78
5.4	Hardware Health Event Monitoring Screen	80

5.5	Security Screen	81
5.6	Boot Screen	82
5.7	Exit Screen	83

# Chapter 1 Introduction



*Because the hardware specifications might be updated, the content of this documentation will be subject to change without notice.*

## 1.1 Package Contents

### **iEP-7030E-020 Series**

- 1 x iEP-7030E-020
- 3 x Screws for M.2 Module
- 1 x Phoenix plug connector
- 1 x System QIG

### **iEP-7030E-021 Series**

- 1 x iEP-7030E-021
- 2 x Screws for M.2 Module
- 1 x Phoenix plug connector
- 1 x System QIG

### **iEP-7030E-022 Series**

- 1 x iEP-7030E-022
- 2 x Screws for M.2 Module
- 1 x Phoenix plug connector
- 1 x System QIG

### **iEP-7030E-023 Series**

- 1 x iEP-7030E-023
- 2 x Screws for M.2 Module
- 1 x Phoenix plug connector
- 1 x System QIG

### **iEP-7030E-024 Series**

- 1 x iEP-7030E-024
- 3 x Screws for M.2 Module
- 1 x Phoenix plug connector
- 1 x System QIG

### **iEP-7030E-025 Series**

- 1 x iEP-7030E-025
- 3 x Screws for M.2 Module
- 1 x Phoenix plug connector
- 1 x System QIG

### **iEP-7031E-020 Series**

- 1 x iEP-7031E-020
- 3 x Screws for M.2 Module
- 1 x Phoenix plug connector
- 1 x System QIG

### **iEP-7031E-021 Series**

- 1 x iEP-7031E-021
- 2 x Screws for M.2 Module
- 1 x Phoenix plug connector
- 1 x System QIG

### **iEP-7031E-022 Series**

- 1 x iEP-7031E-022
- 2 x Screws for M.2 Module
- 1 x Phoenix plug connector
- 1 x System QIG

### **iEP-7031E-023 Series**

- 1 x iEP-7031E-023
- 2 x Screws for M.2 Module
- 1 x Phoenix plug connector
- 1 x System QIG

### **iEP-7031E-024 Series**

- 1 x iEP-7031E-024
- 3 x Screws for M.2 Module
- 1 x Phoenix plug connector
- 1 x System QIG

**iEP-7031E-025 Series**

- 1 x iEP-7031E-025
- 3 x Screws for M.2 Module
- 1 x Phoenix plug connector
- 1 x System QIG



*If any items are missing or appear damaged, contact your authorized dealer.*

## 1.2 Order Information

Model Name	PN	SKU	CPU	Description
iEP-7030E-020	90PXGCU0-00000000	Basic SKU	155H	W/O RAM, SSD, Adapter
iEP-7030E-021	90PXGCU0-10000000	PoE SKU	155H	W/O RAM, SSD, Adapter
iEP-7030E-022	90PXGCU0-20000000	5LAN-WIFI SKU	155H	W/O RAM, SSD, Adapter
iEP-7030E-023	90PXGCU0-30000000	5LAN-5G SKU	155H	W/O RAM, SSD, Adapter
iEP-7030E-024	90PXGCU0-40000000	5G-WIFI SKU	155H	W/O RAM, SSD, Adapter
iEP-7030E-025	90PXGCU0-50000000	8DIO SKU	155H	W/O RAM, SSD, Adapter
iEP-7031E-020	90PXGE30-01000000	Basic SKU	125H	W/O RAM, SSD, Adapter
iEP-7031E-021	90PXGE30-11000000	PoE SKU	125H	W/O RAM, SSD, Adapter
iEP-7031E-022	90PXGE30-21000000	5LAN-WIFI SKU	125H	W/O RAM, SSD, Adapter
iEP-7031E-023	90PXGE30-31000000	5LAN-5G SKU	125H	W/O RAM, SSD, Adapter
iEP-7031E-024	90PXGE30-41000000	5G-WIFI SKU	125H	W/O RAM, SSD, Adapter
iEP-7031E-025	90PXGE30-51000000	8DIO SKU	125H	W/O RAM, SSD, Adapter

### 1.3 Optional Items

Model Name	PN	Description
Wall Mount Kits	13G020760000AI	Attach the wall mounting brackets to the iEP-7030E Series.
Din Rail Kits	13G020761000AI	Attach the Din Rail brackets to the iEP-7030E Series to place the system onto the Din Rail.
Wall Mount Kit	13G0207860A0AI	Attach the wall mounting brackets to the Basic SKU and 8DIO SKU.
VESA Mount Kit	13G020554010AI	Attach the VESA mount brackets to the Basic SKU and 8DIO SKU.
4G LTE KITS	90PCA2P0-00000004	4G Module x1, Antena x2, SMA Cable x2
5G KITS	90PCA2P0-00000003	5G Module x1, Antena x4, SMA Cable x4
WIFI KITS	90PCA2P0-00000000	WIFI Module x1, Antena x2, SMA Cable x2
Adapter	04G266001001AI	Adapter 120W 19V W/O CONN (For Basic/5LAN/5G/8DIO SKU)
	04G266001200AI	Adapter 330W 19V W/O CONN (For PoE SKU)

## 1.4 Product Specifications

### 1.4.1 System : iEP-7030E-020

Processor	CPU	Intel® Core™ Ultra Processor 155H
	Frequency	1.40GHz
	TDP	28W
	BIOS	AMI EFI 256 Mbit
Memory	Technology	DDR5 5600 MHz
	Max Capacity	64GB
	Socket	Dual 262-pin SO-DIMM
Graphics	Chipset	Intel® Arc™ graphics
	Interface	1 x HDMI 2.0b 1 x VGA"
Expansion Slots	RF&Antenna	7 x Antenna Hole
	M.2	1 x M.2 3042/3052 Key B (PCIe Gen3x1/USB3.2 mode) 1 x M.2 2230/2260 Key E (CNVio/CNVio2/PCIe Gen3x1/USB2.0 mode) - Support Wifi/BT Module
	SIM Slot	1 x Nano SIM Card
	SD Slot	1 x Micro SD Card (SD specification v3.0 UHS-I: SDR25/SDR50)
Audio	Interface	Realtek ALC897, High Definition Audio, Mic-In, Line-Out
Ethernet	LAN1	Intel I226-IT, 10/100/1000/2500Mbps, RJ45, 8P8C
	LAN2	Intel I226-IT, 10/100/1000/2500Mbps, RJ45, 8P8C
	LAN3	Intel I226-IT, 10/100/1000/2500Mbps, RJ45, 8P8C
Storage	M.2	1 x M.2 2280 Key M (PCIe Gen4x4)
I/O Interface	Serial Port	3 x RS-232/422/485 (9-pin D-sub connector)
	USB	3 x USB3.2 Gen2x1, 1 x USB2
	GPIO	8-bit Programmable DIO
	Function	1 x Power on button with LED 2 x Diagnostic LED 2 x DC-IN LED
Security	Watch Dog	255-level timer interval, set up through software
	TPM	TPM 2.0
Power Requirement	Input 1	DC 9V to 36V, Redundant Power Input
	Input 2	DC 9V to 36V, Redundant Power Input
	Interface	3-pin Terminal Block : V+, V-, Ground
Environment	Operating Temp.	-25°C ~ 50°C (-13°F~122°F), w/airflow 0.5~0.8m/s
	Storage Temp.	-40°C ~ 85°C (-40°F~185°F)
	Humidity	~95% @ 40°C (non-condensing)
	Shock	Operating with SSD: 100 G, half sine 11 ms duration
	Vibration	Operating with SSD: 5 Grms, 5-500 Hz, 3 axes
	ESD	Contact +/-8 KV, Air +/-15 KV
	EMC	CE and FCC Class A (EN61000-6-4/-2)
	Safety	LVD
Mechanical	Mounting	Din-Rail, Wall Mount, VESA Mount (Optional)
	Dimensions	58mm (W) x 134mm (D) x 170mm (H)
	Net Weight	TBD
Add-on Support	OS	Windows 11, Linux

## 1.4.2 System : iEP-7031E-020

Processor	CPU	Intel® Core™ Ultra Processor 125H
	Frequency	1.20GHz
	TDP	28W
	BIOS	AMI EFI 256 Mbit
Memory	Technology	DDR5 5600 MHz
	Max Capacity	64GB
	Socket	Dual 262-pin SO-DIMM
Graphics	Chipset	Intel® Arc™ graphics
	Interface	1 x HDMI 2.0b 1 x VGA
Expansion Slots	RF&Antenna	7 x Antenna Hole
	M.2	1 x M.2 3042/3052 Key B (PCIe Gen3x1/USB3.2 mode) 1 x M.2 2230/2260 Key E (CNVio/CNVio2/PCIe Gen3x1/USB2.0 mode) - Support Wifi/BT Module
	SIM Slot	1 x Nano SIM Card
	SD Slot	1 x Micro SD Card (SD specification v3.0 UHS-I: SDR25/SDR50)
Audio	Interface	Realtek ALC897, High Definition Audio, Mic-In, Line-Out
Ethernet	LAN1	Intel I226-IT, 10/100/1000/2500Mbps, RJ45, 8P8C
	LAN2	Intel I226-IT, 10/100/1000/2500Mbps, RJ45, 8P8C
	LAN3	Intel I226-IT, 10/100/1000/2500Mbps, RJ45, 8P8C
Storage	M.2	1 x M.2 2280 Key M (PCIe Gen4x4)
I/O Interface	Serial Port	3 x RS-232/422/485 (9-pin D-sub connector)
	USB	3 x USB3.2 Gen2x1, 1 x USB2
	GPIO	8-bit Programmable DIO
	Function	1 x Power on button with LED 2 x Diagnostic LED 2 x DC-IN LED
Security	Watch Dog	255-level timer interval, set up through software
	TPM	TPM 2.0
Power Requirement	Input 1	DC 9V to 36V, Redundant Power Input
	Input 2	DC 9V to 36V, Redundant Power Input
	Interface	3-pin Terminal Block : V+, V-, Ground
Environment	Operating Temp.	-25°C ~ 50°C (-13°F~122°F), w/airflow 0.5~0.8m/s
	Storage Temp.	-40°C ~ 85°C (-40°F~185°F)
	Humidity	~95% @ 40°C (non-condensing)
	Shock	Operating with SSD: 100 G, half sine 11 ms duration
	Vibration	Operating with SSD: 5 Grms, 5-500 Hz, 3 axes
	ESD	Contact +/-8 KV, Air +/-15 KV
	EMC	CE and FCC Class A (EN61000-6-4/-2)
	Safety	LVD
Mechanical	Mounting	Din-Rail, Wall Mount, VESA Mount (Optional)
	Dimensions	58mm (W) x 134mm (D) x 170mm (H)
	Net Weight	TBD
Add-on Support	OS	Windows 11, Linux

### 1.4.3 System : iEP-7030E-021

Processor	CPU	Intel® Core™ Ultra Processor 155H
	Frequency	1.40GHz
	TDP	28W
	BIOS	AMI EFI 256 Mbit
Memory	Technology	DDR5 5600 MHz
	Max Capacity	64GB
	Socket	Dual 262-pin SO-DIMM
Graphics	Chipset	Intel® Arc™ graphics
	Interface	1 x HDMI 2.0b 1 x VGA
Expansion Slots	RF&Antenna	5 x Antenna Hole
	M.2	1 x M.2 3042/3052 Key B (PCIe Gen3.1/USB3.2 mode) - Support PoE Module 1 x M.2 2230/2260 Key E (CNVio/CNVio2/PCIe Gen3x1/USB2.0 mode) - Support Wifi/BT Module
	SIM Slot	1 x Nano SIM Card
	SD Slot	1 x Micro SD Card (SD specification v3.0 UHS-I: SDR25/SDR50)
Audio	Interface	Realtek ALC897, High Definition Audio, Mic-In, Line-Out
Ethernet	LAN1	Intel I226-IT, 10/100/1000/2500Mbps, RJ45, 8P8C
	LAN2	Intel I226-IT, 10/100/1000/2500Mbps, RJ45, 8P8C
	LAN3	Intel I226-IT, 10/100/1000/2500Mbps, RJ45, 8P8C
	LAN4/PoE1	Intel I210-AT, supports IEEE 802.3AF PoE, RJ45, 8P8C
	LAN5/PoE2	Intel I210-AT, supports IEEE 802.3AF PoE, RJ45, 8P8C
Storage	M.2	1 x M.2 2280 Key M (PCIe Gen4x4)
I/O Interface	Serial Port	3 x RS-232/422/485 (9-pin D-sub connector)
	USB	3 x USB3.2 Gen2x1, 1 x USB2
	GPIO	8-bit Programmable DIO
	Function	1 x Power on button with LED 2 x Diagnostic LED 2 x DC-IN LED
Security	Watch Dog	255-level timer interval, set up through software
	TPM	TPM 2.0
Power Requirement	Input 1	DC 19V to 36V, Redundant Power Input
	Input 2	DC 19V to 36V, Redundant Power Input
	Interface	3-pin Terminal Block : V+, V-, Ground
Environment	Operating Temp.	-25°C ~ 50°C (-13°F~122°F), w/airflow 0.5~0.8m/s
	Storage Temp.	-40°C ~ 85°C (-40°F~185°F)
	Humidity	~95% @ 40°C (non-condensing)
	Shock	Operating with SSD: 100 G, half sine 11 ms duration
	Vibration	Operating with SSD: 5 Grms, 5-500 Hz, 3 axes
	ESD	Contact +/-8 KV, Air +/-15 KV
	EMC	CE and FCC Class A (EN61000-6-4/-2)
	Safety	LVD
Mechanical	Mounting	Din-Rail, Wall Mount (Optional)
	Dimensions	68mm (W) x 134mm (D) x 170mm (H)
	Net Weight	TBD
Add-on Support	OS	Windows 11, Linux

## 1.4.4 System : iEP-7031E-021

Processor	CPU	Intel® Core™ Ultra Processor 125H
	Frequency	1.20GHz
	TDP	28W
	BIOS	AMI EFI 256 Mbit
Memory	Technology	DDR5 5600 MHz
	Max Capacity	64GB
Graphics	Socket	Dual 262-pin SO-DIMM
	Chipset	Intel® Arc™ graphics
Graphics	Interface	1 x HDMI 2.0b 1 x VGA
	RF&Antenna	5 x Antenna Hole
Expansion Slots	M.2	1 x M.2 3042/3052 Key B (PCIe Gen3.1/USB3.2 mode) - Support PoE Module 1 x M.2 2230/2260 Key E (CNVio/CNVio2/PCIe Gen3x1/USB2.0 mode) - Support Wifi/BT Module
	SIM Slot	1 x Nano SIM Card
	SD Slot	1 x Micro SD Card (SD specification v3.0 UHS-I; SDR25/SDR50)
Audio	Interface	Realtek ALC897, High Definition Audio, Mic-In, Line-Out
Ethernet	LAN1	Intel I226-IT, 10/100/1000/2500Mbps, RJ45, 8P8C
	LAN2	Intel I226-IT, 10/100/1000/2500Mbps, RJ45, 8P8C
	LAN3	Intel I226-IT, 10/100/1000/2500Mbps, RJ45, 8P8C
	LAN4/PoE1	Intel I210-AT, supports IEEE 802.3AF PoE, RJ45, 8P8C
	LAN5/PoE2	Intel I210-AT, supports IEEE 802.3AF PoE, RJ45, 8P8C
Storage	M.2	1 x M.2 2280 Key M (PCIe Gen4x4)
I/O Interface	Serial Port	3 x RS-232/422/485 (9-pin D-sub connector)
	USB	3 x USB3.2 Gen2x1, 1 x USB2
	GPIO	8-bit Programmable DIO
	Function	1 x Power on button with LED 2 x Diagnostic LED 2 x DC-IN LED
Security	Watch Dog	255-level timer interval, set up through software
	TPM	TPM 2.0
Power Requirement	Input 1	DC 19V to 36V, Redundant Power Input
	Input 2	DC 19V to 36V, Redundant Power Input
	Interface	3-pin Terminal Block : V+, V-, Ground
Environment	Operating Temp.	-25°C ~ 50°C (-13°F~122°F), w/airflow 0.5~0.8m/s
	Storage Temp.	-40°C ~ 85°C (-40°F~185°F)
	Humidity	~95% @ 40°C (non-condensing)
	Shock	Operating with SSD: 100 G, half sine 11 ms duration
	Vibration	Operating with SSD: 5 Grms, 5-500 Hz, 3 axes
	ESD	Contact +/-8 KV, Air +/-15 KV
	EMC	CE and FCC Class A (EN61000-6-4/-2)
	Safety	LVD
Mechanical	Mounting	Din-Rail, Wall Mount (Optional)
	Dimensions	68mm (W) x 134mm (D) x 170mm (H)
	Net Weight	TBD
Add-on Support	OS	Windows 11, Linux

## 1.4.5 System : iEP-7030E-022

Processor	CPU	Intel® Core™ Ultra Processor 155H
	Frequency	1.40GHz
	TDP	28W
	BIOS	AMI EFI 256 Mbit
Memory	Technology	DDR5 5600 MHz
	Max Capacity	64GB
	Socket	Dual 262-pin SO-DIMM
Graphics	Chipset	Intel® Arc™ graphics
	Interface	1 x HDMI 2.0b 1 x VGA
Expansion Slots	RF&Antenna	5 x Antenna Hole
	M.2	1 x M.2 3042/3052 Key B (PCIe Gen3.1/USB3.2 mode) - Support 2-LAN Port Module 1 x M.2 2230/2260 Key E (CNVio/CNVio2/PCIe Gen3x1/USB2.0 mode) - Support Wifi/BT Module
	SIM Slot	1 x Nano SIM Card
	SD Slot	1 x Micro SD Card (SD specification v3.0 UHS-I: SDR25/SDR50)
Audio	Interface	Realtek ALC897, High Definition Audio, Mic-In, Line-Out
Ethernet	LAN1	Intel I226-IT, 10/100/1000/2500Mbps, RJ45, 8P8C
	LAN2	Intel I226-IT, 10/100/1000/2500Mbps, RJ45, 8P8C
	LAN3	Intel I226-IT, 10/100/1000/2500Mbps, RJ45, 8P8C
	LAN4	Intel I210-AT, 10/100/1000Mbps, RJ45, 8P8C
	LAN5	Intel I210-AT, 10/100/1000Mbps, RJ45, 8P8C
Storage	M.2	1 x M.2 2280 Key M (PCIe Gen4x4)
I/O Interface	Serial Port	3 x RS-232/422/485 (9-pin D-sub connector)
	USB	3 x USB3.2 Gen2x1, 1 x USB2
	GPIO	8-bit Programmable DIO
	Function	1 x Power on button with LED 2 x Diagnostic LED 2 x DC-IN LED
Security	Watch Dog	255-level timer interval, set up through software
	TPM	TPM 2.0
Power Requirement	Input 1	DC 9V to 36V, Redundant Power Input
	Input 2	DC 9V to 36V, Redundant Power Input
	Interface	3-pin Terminal Block : V+, V-, Ground
Environment	Operating Temp.	-25°C ~ 50°C (-13°F~122°F), w/airflow 0.5~0.8m/s
	Storage Temp.	-40°C ~ 85°C (-40°F~185°F)
	Humidity	~95% @ 40°C (non-condensing)
	Shock	Operating with SSD: 100 G, half sine 11 ms duration
	Vibration	Operating with SSD: 5 Grms, 5-500 Hz, 3 axes
	ESD	Contact +/-8 KV, Air +/-15 KV
	EMC	CE and FCC Class A (EN61000-6-4/-2)
	Safety	LVD
Mechanical	Mounting	Din-Rail, Wall Mount (Optional)
	Dimensions	68mm (W) x 134mm (D) x 170mm (H)
	Net Weight	TBD
Add-on Support	OS	Windows 11, Linux

## 1.4.6 System : iEP-7031E-022

Processor	CPU	Intel® Core™ Ultra Processor 125H
	Frequency	1.20GHz
	TDP	28W
	BIOS	AMI EFI 256 Mbit
Memory	Technology	DDR5 5600 MHz
	Max Capacity	64GB
	Socket	Dual 262-pin SO-DIMM
Graphics	Chipset	Intel® Arc™ graphics
	Interface	1 x HDMI 2.0b 1 x VGA
Expansion Slots	RF&Antenna	5 x Antenna Hole
	M.2	1 x M.2 3042/3052 Key B (PCIe Gen3.1/USB3.2 mode) - Support 2-LAN Port Module 1 x M.2 2230/2260 Key E (CNVio/CNVio2/PCIe Gen3x1/USB2.0 mode) - Support Wifi/BT Module
	SIM Slot	1 x Nano SIM Card
	SD Slot	1 x Micro SD Card (SD specification v3.0 UHS-I: SDR25/SDR50)
Audio	Interface	Realtek ALC897, High Definition Audio, Mic-In, Line-Out
Ethernet	LAN1	Intel I226-IT, 10/100/1000/2500Mbps, RJ45, 8P8C
	LAN2	Intel I226-IT, 10/100/1000/2500Mbps, RJ45, 8P8C
	LAN3	Intel I226-IT, 10/100/1000/2500Mbps, RJ45, 8P8C
	LAN4	Intel I210-AT, 10/100/1000Mbps, RJ45, 8P8C
	LAN5	Intel I210-AT, 10/100/1000Mbps, RJ45, 8P8C
Storage	M.2	1 x M.2 2280 Key M (PCIe Gen4x4)
I/O Interface	Serial Port	3 x RS-232/422/485 (9-pin D-sub connector)
	USB	3 x USB3.2 Gen2x1, 1 x USB2
	GPIO	8-bit Programmable DIO
	Function	1 x Power on button with LED 2 x Diagnostic LED 2 x DC-IN LED
Security	Watch Dog	255-level timer interval, set up through software
	TPM	TPM 2.0
Power Requirement	Input 1	DC 9V to 36V, Redundant Power Input
	Input 2	DC 9V to 36V, Redundant Power Input
	Interface	3-pin Terminal Block : V+, V-, Ground
Environment	Operating Temp.	-25°C ~ 50°C (-13°F~122°F), w/airflow 0.5~0.8m/s
	Storage Temp.	-40°C ~ 85°C (-40°F~185°F)
	Humidity	~95% @ 40°C (non-condensing)
	Shock	Operating with SSD: 100 G, half sine 11 ms duration
	Vibration	Operating with SSD: 5 Grms, 5-500 Hz, 3 axes
	ESD	Contact +/-8 KV, Air +/-15 KV
	EMC	CE and FCC Class A (EN61000-6-4/-2)
	Safety	LVD
Mechanical	Mounting	Din-Rail, Wall Mount (Optional)
	Dimensions	68mm (W) x 134mm (D) x 170mm (H)
	Net Weight	TBD
Add-on Support	OS	Windows 11, Linux

## 1.4.7 System : iEP-7030E-023

Processor	CPU	Intel® Core™ Ultra Processor 155H
	Frequency	1.40GHz
	TDP	28W
	BIOS	AMI EFI 256 Mbit
Memory	Technology	DDR5 5600 MHz
	Max Capacity	64GB
	Socket	Dual 262-pin SO-DIMM
Graphics	Chipset	Intel® Arc™ graphics
	Interface	1 x HDMI 2.0b 1 x VGA
Expansion Slots	RF&Antenna	5 x Antenna Hole
	M.2	1 x M.2 3042/3052 Key B (PCIe Gen3.1/USB3.2 mode) - Support 4G LTE/5G Module 1 x M.2 2230/2260 Key E (CNVio/CNVio2/PCIe Gen3x1/USB2.0 mode) - Support 2-LAN Port Module
	SIM Slot	1 x Nano SIM Card
	SD Slot	1 x Micro SD Card (SD specification v3.0 UHS-I: SDR25/SDR50)
Audio	Interface	Realtek ALC897, High Definition Audio, Mic-In, Line-Out
Ethernet	LAN1	Intel I226-IT, 10/100/1000/2500Mbps, RJ45, 8P8C
	LAN2	Intel I226-IT, 10/100/1000/2500Mbps, RJ45, 8P8C
	LAN3	Intel I226-IT, 10/100/1000/2500Mbps, RJ45, 8P8C
	LAN4	Intel I210-AT, 10/100/1000Mbps, RJ45, 8P8C
	LAN5	Intel I210-AT, 10/100/1000Mbps, RJ45, 8P8C
Storage	M.2	1 x M.2 2280 Key M (PCIe Gen4x4)
I/O Interface	Serial Port	3 x RS-232/422/485 (9-pin D-sub connector)
	USB	3 x USB3.2 Gen2x1, 1 x USB2
	GPIO	8-bit Programmable DIO
	Function	1 x Power on button with LED 2 x Diagnostic LED 2 x DC-IN LED
Security	Watch Dog	255-level timer interval, set up through software
	TPM	TPM 2.0
Power Requirement	Input 1	DC 9V to 36V, Redundant Power Input
	Input 2	DC 9V to 36V, Redundant Power Input
	Interface	3-pin Terminal Block : V+, V-, Ground
Environment	Operating Temp.	-25°C ~ 50°C (-13°F~122°F), w/airflow 0.5~0.8m/s
	Storage Temp.	-40°C ~ 85°C (-40°F~185°F)
	Humidity	~95% @ 40°C (non-condensing)
	Shock	Operating with SSD: 100 G, half sine 11 ms duration
	Vibration	Operating with SSD: 5 Grms, 5-500 Hz, 3 axes
	ESD	Contact +/-8 KV, Air +/-15 KV
	EMC	CE and FCC Class A (EN61000-6-4/-2)
	Safety	LVD
Mechanical	Mounting	Din-Rail, Wall Mount (Optional)
	Dimensions	68mm (W) x 134mm (D) x 170mm (H)
	Net Weight	TBD
Add-on Support	OS	Windows 11, Linux

## 1.4.8 System : iEP-7031E-023

Processor	CPU	Intel® Core™ Ultra Processor 125H
	Frequency	1.20GHz
	TDP	28W
	BIOS	AMI EFI 256 Mbit
Memory	Technology	DDR5 5600 MHz
	Max Capacity	64GB
Graphics	Socket	Dual 262-pin SO-DIMM
	Chipset	Intel® Arc™ graphics
	Interface	1 x HDMI 2.0b 1 x VGA
Expansion Slots	RF&Antenna	5 x Antenna Hole
	M.2	1 x M.2 3042/3052 Key B (PCIe Gen3.1/USB3.2 mode) - Support 4G LTE/5G Module 1 x M.2 2230/2260 Key E (CNVio/CNVio2/PCIe Gen3x1/USB2.0 mode) - Support 2-LAN Port Module
	SIM Slot	1 x Nano SIM Card
	SD Slot	1 x Micro SD Card (SD specification v3.0 UHS-I; SDR25/SDR50)
Audio	Interface	Realtek ALC897, High Definition Audio, Mic-In, Line-Out
Ethernet	LAN1	Intel I226-IT, 10/100/1000/2500Mbps, RJ45, 8P8C
	LAN2	Intel I226-IT, 10/100/1000/2500Mbps, RJ45, 8P8C
	LAN3	Intel I226-IT, 10/100/1000/2500Mbps, RJ45, 8P8C
	LAN4	Intel I210-AT, 10/100/1000Mbps, RJ45, 8P8C
	LAN5	Intel I210-AT, 10/100/1000Mbps, RJ45, 8P8C
Storage	M.2	1 x M.2 2280 Key M (PCIe Gen4x4)
I/O Interface	Serial Port	3 x RS-232/422/485 (9-pin D-sub connector)
	USB	3 x USB3.2 Gen2x1, 1 x USB2
	GPIO	8-bit Programmable DIO
	Function	1 x Power on button with LED 2 x Diagnostic LED 2 x DC-IN LED
Security	Watch Dog	255-level timer interval, set up through software
	TPM	TPM 2.0
Power Requirement	Input 1	DC 9V to 36V, Redundant Power Input
	Input 2	DC 9V to 36V, Redundant Power Input
	Interface	3-pin Terminal Block : V+, V-, Ground
Environment	Operating Temp.	-25°C ~ 50°C (-13°F~122°F), w/airflow 0.5~0.8m/s
	Storage Temp.	-40°C ~ 85°C (-40°F~185°F)
	Humidity	~95% @ 40°C (non-condensing)
	Shock	Operating with SSD: 100 G, half sine 11 ms duration
	Vibration	Operating with SSD: 5 Grms, 5-500 Hz, 3 axes
	ESD	Contact +/-8 KV, Air +/-15 KV
	EMC	CE and FCC Class A (EN61000-6-4/-2)
	Safety	LVD
Mechanical	Mounting	Din-Rail, Wall Mount (Optional)
	Dimensions	68mm (W) x 134mm (D) x 170mm (H)
	Net Weight	TBD
Add-on Support	OS	Windows 11, Linux

## 1.4.9 System : iEP-7030E-024

Processor	CPU	Intel® Core™ Ultra Processor 155H
	Frequency	1.40GHz
	TDP	28W
	BIOS	AMI EFI 256 Mbit
Memory	Technology	DDR5 5600 MHz
	Max Capacity	64GB
	Socket	Dual 262-pin SO-DIMM
Graphics	Chipset	Intel® Arc™ graphics
	Interface	1 x HDMI 2.0b 1 x VGA
Expansion Slots	RF&Antenna	7 x Antenna Hole
	M.2	1 x M.2 3042/3052 Key B (PCIe Gen3.1/USB3.2 mode) - Support 4G LTE/5G Module 1 x M.2 2230/2260 Key E (CNVio/CNVio2/PCIe Gen3x1/USB2.0 mode) - Support Wifi/BT Module
	SIM Slot	1 x Nano SIM Card
	SD Slot	1 x Micro SD Card (SD specification v3.0 UHS-I: SDR25/SDR50)
Audio	Interface	Realtek ALC897, High Definition Audio, Mic-In, Line-Out
Ethernet	LAN1	Intel I226-IT, 10/100/1000/2500Mbps, RJ45, 8P8C
	LAN2	Intel I226-IT, 10/100/1000/2500Mbps, RJ45, 8P8C
	LAN3	Intel I226-IT, 10/100/1000/2500Mbps, RJ45, 8P8C
Storage	M.2	1 x M.2 2280 Key M (PCIe Gen4x4)
I/O Interface	Serial Port	3 x RS-232/422/485 (9-pin D-sub connector)
	USB	3 x USB3.2 Gen2x1, 1 x USB2
	GPIO	8-bit Programmable DIO
	Function	1 x Power on button with LED 2 x Diagnostic LED 2 x DC-IN LED
Security	Watch Dog	255-level timer interval, set up through software
	TPM	TPM 2.0
Power Requirement	Input 1	DC 9V to 36V, Redundant Power Input
	Input 2	DC 9V to 36V, Redundant Power Input
	Interface	3-pin Terminal Block : V+, V-, Ground
Environment	Operating Temp.	-25°C ~ 50°C (-13°F~122°F), w/airflow 0.5~0.8m/s
	Storage Temp.	-40°C ~ 85°C (-40°F~185°F)
	Humidity	~95% @ 40°C (non-condensing)
	Shock	Operating with SSD: 100 G, half sine 11 ms duration
	Vibration	Operating with SSD: 5 Grms, 5-500 Hz, 3 axes
	ESD	Contact +/- 8 KV, Air +/- 15 KV
	EMC	CE and FCC Class A (EN61000-6-4/-2)
Mechanical	Safety	LVD
	Mounting	Din-Rail, Wall Mount (Optional)
	Dimensions	68mm (W) x 134mm (D) x 170mm (H)
Add-on Support	Net Weight	TBD
	OS	Windows 11, Linux

## 1.4.10 System : iEP-7031E-024

Processor	CPU	Intel® Core™ Ultra Processor 125H
	Frequency	1.20GHz
	TDP	28W
	BIOS	AMI EFI 256 Mbit
Memory	Technology	DDR5 5600 MHz
	Max Capacity	64GB
	Socket	Dual 262-pin SO-DIMM
Graphics	Chipset	Intel® Arc™ graphics
	Interface	1 x HDMI 2.0b 1 x VGA
Expansion Slots	RF&Antenna	7 x Antenna Hole
	M.2	1 x M.2 3042/3052 Key B (PCIe Gen3.1/USB3.2 mode) - Support 4G LTE/5G Module 1 x M.2 2230/2260 Key E (CNVio/CNVio2/PCIe Gen3x1/USB2.0 mode) - Support Wifi/BT Module
	SIM Slot	1 x Nano SIM Card
	SD Slot	1 x Micro SD Card (SD specification v3.0 UHS-I: SDR25/SDR50)
Audio	Interface	Realtek ALC897, High Definition Audio, Mic-In, Line-Out
Ethernet	LAN1	Intel I226-IT, 10/100/1000/2500Mbps, RJ45, 8P8C
	LAN2	Intel I226-IT, 10/100/1000/2500Mbps, RJ45, 8P8C
	LAN3	Intel I226-IT, 10/100/1000/2500Mbps, RJ45, 8P8C
Storage	M.2	1 x M.2 2280 Key M (PCIe Gen4x4)
I/O Interface	Serial Port	3 x RS-232/422/485 (9-pin D-sub connector)
	USB	3 x USB3.2 Gen2x1, 1 x USB2
	GPIO	8-bit Programmable DIO
	Function	1 x Power on button with LED 2 x Diagnostic LED 2 x DC-IN LED
Security	Watch Dog	255-level timer interval, set up through software
	TPM	TPM 2.0
Power Requirement	Input 1	DC 9V to 36V, Redundant Power Input
	Input 2	DC 9V to 36V, Redundant Power Input
	Interface	3-pin Terminal Block : V+, V-, Ground
Environment	Operating Temp.	-25°C ~ 50°C (-13°F~122°F), w/airflow 0.5~0.8m/s
	Storage Temp.	-40°C ~ 85°C (-40°F~185°F)
	Humidity	~95% @ 40°C (non-condensing)
	Shock	Operating with SSD: 100 G, half sine 11 ms duration
	Vibration	Operating with SSD: 5 Grms, 5-500 Hz, 3 axes
	ESD	Contact +/- 8 KV, Air +/- 15 KV
	EMC	CE and FCC Class A (EN61000-6-4/-2)
Safety	LVD	
Mechanical	Mounting	Din-Rail, Wall Mount (Optional)
	Dimensions	68mm (W) x 134mm (D) x 170mm (H)
	Net Weight	TBD
Add-on Support	OS	Windows 11, Linux

## 1.4.11 System : iEP-7030E-025

Processor	CPU	Intel® Core™ Ultra Processor 155H
	Frequency	1.40GHz
	TDP	28W
	BIOS	AMI EFI 256 Mbit
Memory	Technology	DDR5 5600 MHz
	Max Capacity	64GB
	Socket	Dual 262-pin SO-DIMM
Graphics	Chipset	Intel® Arc™ graphics
	Interface	1 x HDMI 2.0b 1 x VGA
Expansion Slots	RF&Antenna	5 x Antenna Hole
	M.2	1 x M.2 3042/3052 Key B (PCIe Gen3.1/USB3.2 mode) 1 x M.2 2230/2260 Key E (CNVio/CNVio2/PCIe Gen3x1/USB2.0 mode) - Support Wifi/BT Module
	SIM Slot	1 x Nano SIM Card
	SD Slot	1 x Micro SD Card (SD specification v3.0 UHS-I: SDR25/SDR50)
Audio	Interface	Realtek ALC897, High Definition Audio, Mic-In, Line-Out
Ethernet	LAN1	Intel I226-IT, 10/100/1000/2500Mbps, RJ45, 8P8C
	LAN2	Intel I226-IT, 10/100/1000/2500Mbps, RJ45, 8P8C
	LAN3	Intel I226-IT, 10/100/1000/2500Mbps, RJ45, 8P8C
Storage	M.2	1 x M.2 2280 Key M (PCIe Gen4x4)
I/O Interface	Serial Port	3 x RS-232/422/485 (9-pin D-sub connector)
	USB	3 x USB3.2 Gen2x1, 1 x USB2
	GPIO	8-bit Programmable DIO
	Digital I/O	8DIs/8DOs with sink/source isolation 36V (2x10-pin connector)
	Function	1 x Power on button with LED 2 x Diagnostic LED 2 x DC-IN LED
Security	Watch Dog	255-level timer interval, set up through software
	TPM	TPM 2.0
Power Requirement	Input 1	DC 9V to 36V, Redundant Power Input
	Input 2	DC 9V to 36V, Redundant Power Input
	Interface	3-pin Terminal Block : V+, V-, Ground
Environment	Operating Temp.	-25°C ~ 50°C (-13°F~122°F), w/airflow 0.5~0.8m/s
	Storage Temp.	-40°C ~ 85°C (-40°F~185°F)
	Humidity	~95% @ 40°C (non-condensing)
	Shock	Operating with SSD: 100 G, half sine 11 ms duration
	Vibration	Operating with SSD: 5 Grms, 5-500 Hz, 3 axes
	ESD	Contact +/-8 KV, Air +/-15 KV
	EMC	CE and FCC Class A (EN61000-6-4/-2)
	Safety	LVD
Mechanical	Mounting	Din-Rail, Wall Mount, VESA Mount (Optional)
	Dimensions	58mm (W) x 134mm (D) x 170mm (H)
	Net Weight	TBD
Add-on Support	OS	Windows 11, Linux

## 1.4.12 System : iEP-7031E-025

Processor	CPU	Intel® Core™ Ultra Processor 125H
	Frequency	1.20GHz
	TDP	28W
	BIOS	AMI EFI 256 Mbit
Memory	Technology	DDR5 5600 MHz
	Max Capacity	64GB
	Socket	Dual 262-pin SO-DIMM
Graphics	Chipset	Intel® Arc™ graphics
	Interface	1 x HDMI 2.0b 1 x VGA
Expansion Slots	RF&Antenna	5 x Antenna Hole
	M.2	1 x M.2 3042/3052 Key B (PCIe Gen3.1/USB3.2 mode) 1 x M.2 2230/2260 Key E (CNVio/CNVio2/PCIe Gen3x1/USB2.0 mode) - Support Wifi/BT Module
	SIM Slot	1 x Nano SIM Card
	SD Slot	1 x Micro SD Card (SD specification v3.0 UHS-I: SDR25/SDR50)
Audio	Interface	Realtek ALC897, High Definition Audio, Mic-In, Line-Out
Ethernet	LAN1	Intel I226-IT, 10/100/1000/2500Mbps, RJ45, 8P8C
	LAN2	Intel I226-IT, 10/100/1000/2500Mbps, RJ45, 8P8C
	LAN3	Intel I226-IT, 10/100/1000/2500Mbps, RJ45, 8P8C
Storage	M.2	1 x M.2 2280 Key M (PCIe Gen4x4)
I/O Interface	Serial Port	3 x RS-232/422/485 (9-pin D-sub connector)
	USB	3 x USB3.2 Gen2x1, 1 x USB2
	GPIO	8-bit Programmable DIO
	Digital I/O	8DIs/8DOs with sink/source isolation 36V (2x10-pin connector)
	Function	1 x Power on button with LED 2 x Diagnostic LED 2 x DC-IN LED
Security	Watch Dog	255-level timer interval, set up through software
	TPM	TPM 2.0
Power Requirement	Input 1	DC 9V to 36V, Redundant Power Input
	Input 2	DC 9V to 36V, Redundant Power Input
	Interface	3-pin Terminal Block : V+, V-, Ground
Environment	Operating Temp.	-25°C ~ 50°C (-13°F~122°F), w/airflow 0.5~0.8m/s
	Storage Temp.	-40°C ~ 85°C (-40°F~185°F)
	Humidity	~95% @ 40°C (non-condensing)
	Shock	Operating with SSD: 100 G, half sine 11 ms duration
	Vibration	Operating with SSD: 5 Grms, 5-500 Hz, 3 axes
	ESD	Contact +/-8 KV, Air +/-15 KV
	EMC	CE and FCC Class A (EN61000-6-4/-2)
Safety	LVD	
Mechanical	Mounting	Din-Rail, Wall Mount, VESA Mount (Optional)
	Dimensions	58mm (W) x 134mm (D) x 170mm (H)
	Net Weight	TBD
Add-on Support	OS	Windows 11, Linux

# 1.5 Block Diagram

## DSB-1130-WT

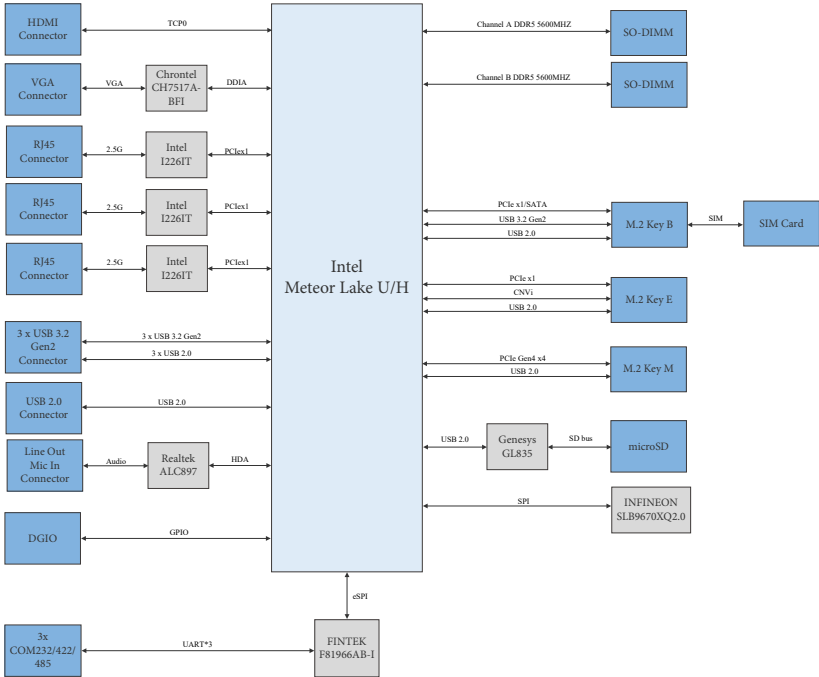

## Chapter 2 Product Overview

This chapter provides diagrams showing the location of important components of the iEP-7030E Series.

### 2.1 System Front Panel

#### 2.1.1 System : iEP-7030E-020, iEP-7031E-020, iEP-7030E-025, iEP-7031E-025

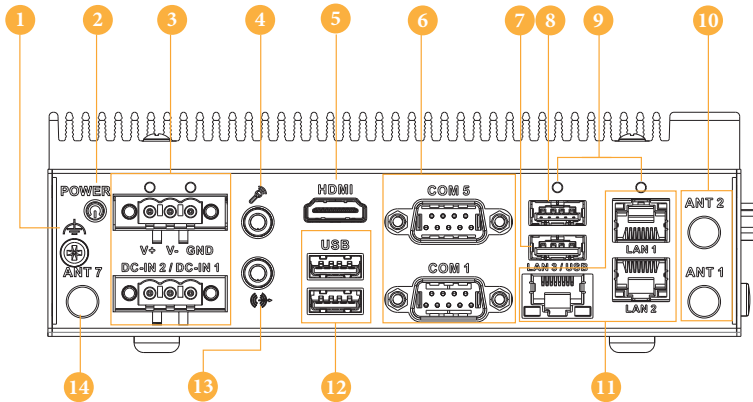

No.	Description
1	<b>Ground:</b> The functional earth ground provides you with a grounding point.
2	<b>Power Button:</b> The power button allows you to turn the iEP-7030E Series on or off. You can use the power button to put your iEP-7030E Series into sleep mode or press it for four seconds to shut down you system.
3	<b>DC-IN Connectors:</b> The V+ and V- pins provide DC power input and the chassis ground pin allows connection of the chassis to ground for better EMC compatibility. The DC power input for the iEP-703XE series supports a voltage input range from 9V to 36V DC.

Pin	Signal name
1	V+
2	V-
3	GND

  

The close-up diagram shows the DC-IN connector with three pins labeled 1, 2, and 3, corresponding to the signal names in the table above.

4	<b>Audio (Mic-In):</b> The Mic-in audio connector on the I/O panel supports 5.1 channel HD audio and fully complies with Intel® High Definition Audio specifications.																																								
5	<b>HDMI:</b> The HDMI port supports a Full-HD device to allow viewing on a larger external display.																																								
6	<p><b>Serial (COM) Ports*:</b> The 9-pin RS232/422/485 serial connector allows you to connect devices that have serial ports.</p> <p>* This motherboard supports RS232/422/485 on COM1, 5 ports. Please refer to table below for the pin definition. In addition, COM1, 5 ports (RS232/422/485) can be adjusted in BIOS setup utility &gt; Advanced Screen &gt; Super IO Configuration. You may refer to our user manual for details.</p> <p style="text-align: center;"><b>COM1, 5 Ports Pin Definition</b></p> <table border="1" style="margin-left: auto; margin-right: auto;"> <thead> <tr> <th>Pin</th> <th>RS232</th> <th>RS422</th> <th>RS485</th> </tr> </thead> <tbody> <tr> <td>1</td> <td>DCD, Data Carrier Detect</td> <td>TX-</td> <td>RTX-</td> </tr> <tr> <td>2</td> <td>RXD, Receive Data</td> <td>TX+</td> <td>RTX+</td> </tr> <tr> <td>3</td> <td>TXD, Transmit Data</td> <td>RX+</td> <td>NA</td> </tr> <tr> <td>4</td> <td>DTR, Data Terminal Ready</td> <td>RX-</td> <td>NA</td> </tr> <tr> <td>5</td> <td>GND</td> <td>GND</td> <td>GND</td> </tr> <tr> <td>6</td> <td>DSR, Data Set Ready</td> <td>NA</td> <td>NA</td> </tr> <tr> <td>7</td> <td>RTS, Request To Send</td> <td>NA</td> <td>NA</td> </tr> <tr> <td>8</td> <td>CTS, Clear To Send</td> <td>NA</td> <td>NA</td> </tr> <tr> <td>9</td> <td>NA</td> <td>NA</td> <td>NA</td> </tr> </tbody> </table>	Pin	RS232	RS422	RS485	1	DCD, Data Carrier Detect	TX-	RTX-	2	RXD, Receive Data	TX+	RTX+	3	TXD, Transmit Data	RX+	NA	4	DTR, Data Terminal Ready	RX-	NA	5	GND	GND	GND	6	DSR, Data Set Ready	NA	NA	7	RTS, Request To Send	NA	NA	8	CTS, Clear To Send	NA	NA	9	NA	NA	NA
Pin	RS232	RS422	RS485																																						
1	DCD, Data Carrier Detect	TX-	RTX-																																						
2	RXD, Receive Data	TX+	RTX+																																						
3	TXD, Transmit Data	RX+	NA																																						
4	DTR, Data Terminal Ready	RX-	NA																																						
5	GND	GND	GND																																						
6	DSR, Data Set Ready	NA	NA																																						
7	RTS, Request To Send	NA	NA																																						
8	CTS, Clear To Send	NA	NA																																						
9	NA	NA	NA																																						
7	<b>USB 2.0 port:</b> The USB port is compatible with USB 2.0 or USB 1.1 devices.																																								
8, 12	<b>USB 3.2 Gen2x1 port :</b> The USB 3.2 Gen2x1 port provides a transfer rate up to 10 Gbit/s.																																								
9	<b>Diagnostic LEDs**:</b> These LEDs indicate the debug status of the motherboard. Please refer to the table below to get more information about the Diagnostic LED.																																								
10, 14	<b>Antenna Holes:</b> The antenna holes allow you to connect a wireless antenna to enhance wireless signal reception.																																								
11	<b>LAN ports***:</b> The RJ45 8P8C LAN port supports a standard Ethernet cable for 10/100/1000/2500 Mbps connection to the local network, is capable of bridging, and can perform auto-negotiation.																																								
13	<b>Audio (Line-Out):</b> The port connects speakers to the Line-out connector for better sound quality.																																								

2.1.2 System : iEP-7030E-021, iEP-7031E-021, iEP-7030E-022, iEP-7031E-022, iEP-7030E-023, iEP-7031E-023, iEP-7030E-024, iEP-7031E-024

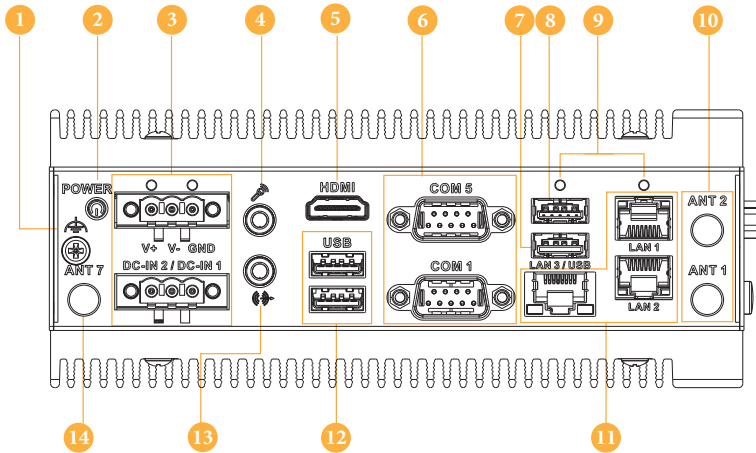

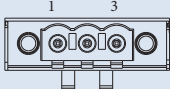
No.	Description								
1	<b>Ground:</b> The functional earth ground provides you with a grounding point.								
2	<b>Power Button:</b> The power button allows you to turn the iEP-7030E Series on or off. You can use the power button to put your iEP-7030E Series into sleep mode or press it for four seconds to shut down your system.								
3	<p><b>DC-IN Connectors:</b> The V+ and V- pins provide DC power input and the chassis ground pin allows connection of the chassis to ground for better EMC compatibility. The DC power input for the iEP-703XE series supports a voltage input range from 9V or 19V to 36V DC.</p> <table border="1" data-bbox="224 1249 520 1337"> <thead> <tr> <th>Pin</th> <th>Signal name</th> </tr> </thead> <tbody> <tr> <td>1</td> <td>V+</td> </tr> <tr> <td>2</td> <td>V-</td> </tr> <tr> <td>3</td> <td>GND</td> </tr> </tbody> </table> 	Pin	Signal name	1	V+	2	V-	3	GND
Pin	Signal name								
1	V+								
2	V-								
3	GND								

4	<b>Audio (Mic-In):</b> The Mic-in audio connector on the I/O panel supports 5.1 channel HD audio and fully complies with Intel® High Definition Audio specifications.																																								
5	<b>HDMI:</b> The HDMI port supports a Full-HD device to allow viewing on a larger external display.																																								
6	<p><b>Serial (COM) Ports*:</b> The 9-pin RS232/422/485 serial connector allows you to connect devices that have serial ports.</p> <p>* This motherboard supports RS232/422/485 on COM1, 5 ports. Please refer to table below for the pin definition. In addition, COM1, 5 ports (RS232/422/485) can be adjusted in BIOS setup utility &gt; Advanced Screen &gt; Super IO Configuration. You may refer to our user manual for details.</p> <p style="text-align: center;"><b>COM1, 5 Ports Pin Definition</b></p> <table border="1" style="margin-left: auto; margin-right: auto;"> <thead> <tr> <th>Pin</th> <th>RS232</th> <th>RS422</th> <th>RS485</th> </tr> </thead> <tbody> <tr> <td>1</td> <td>DCD, Data Carrier Detect</td> <td>TX-</td> <td>RTX-</td> </tr> <tr> <td>2</td> <td>RXD, Receive Data</td> <td>TX+</td> <td>RTX+</td> </tr> <tr> <td>3</td> <td>TXD, Transmit Data</td> <td>RX+</td> <td>NA</td> </tr> <tr> <td>4</td> <td>DTR, Data Terminal Ready</td> <td>RX-</td> <td>NA</td> </tr> <tr> <td>5</td> <td>GND</td> <td>GND</td> <td>GND</td> </tr> <tr> <td>6</td> <td>DSR, Data Set Ready</td> <td>NA</td> <td>NA</td> </tr> <tr> <td>7</td> <td>RTS, Request To Send</td> <td>NA</td> <td>NA</td> </tr> <tr> <td>8</td> <td>CTS, Clear To Send</td> <td>NA</td> <td>NA</td> </tr> <tr> <td>9</td> <td>NA</td> <td>NA</td> <td>NA</td> </tr> </tbody> </table>	Pin	RS232	RS422	RS485	1	DCD, Data Carrier Detect	TX-	RTX-	2	RXD, Receive Data	TX+	RTX+	3	TXD, Transmit Data	RX+	NA	4	DTR, Data Terminal Ready	RX-	NA	5	GND	GND	GND	6	DSR, Data Set Ready	NA	NA	7	RTS, Request To Send	NA	NA	8	CTS, Clear To Send	NA	NA	9	NA	NA	NA
Pin	RS232	RS422	RS485																																						
1	DCD, Data Carrier Detect	TX-	RTX-																																						
2	RXD, Receive Data	TX+	RTX+																																						
3	TXD, Transmit Data	RX+	NA																																						
4	DTR, Data Terminal Ready	RX-	NA																																						
5	GND	GND	GND																																						
6	DSR, Data Set Ready	NA	NA																																						
7	RTS, Request To Send	NA	NA																																						
8	CTS, Clear To Send	NA	NA																																						
9	NA	NA	NA																																						
7	<b>USB 2.0 port:</b> The USB port is compatible with USB 2.0 or USB 1.1 devices.																																								
8, 12	<b>USB 3.2 Gen2x1 port :</b> The USB 3.2 Gen2x1 port provides a transfer rate up to 10 Gbit/s.																																								
9	<b>Diagnostic LEDs**:</b> These LEDs indicate the debug status of the motherboard. Please refer to the table below to get more information about the Diagnostic LEDs.																																								
10, 14	<b>Antenna Holes:</b> The antenna holes allow you to connect a wireless antenna to enhance wireless signal reception.																																								
11	<b>LAN ports***:</b> The RJ45 8P8C LAN port supports a standard Ethernet cable for 10/100/1000/2500 Mbps connection to the local network, is capable of bridging, and can perform auto-negotiation.																																								
13	<b>Audio (Line-Out):</b> The port connects speakers to the Line-out connector for better sound quality.																																								
15	<b>Antenna Hole:</b> The antenna hole allows you to connect a wireless antenna to enhance wireless signal reception.																																								

\*\* Please refer to the table below for the Diagnostic LED indications.

Item	LED1	LED2	BIOS Status Code	Description
CPU	White	White	0x15	PEI_CAR_NB_INIT
	White	Blue	0x32	PEI_CPU_INIT
	White	Yellow	0x68	DXE_NB_HB_INIT
	White	Red	0x19	PEI_CAR_SB_INIT
DRAM	Blue	White	0x4F	PEI_DXE_IPL_STARTED
	Blue	Blue	0x51	PEI_MEMORY_SPD_FAIL
	Blue	Yellow	0x53	PEI_MEMORY_NOT_DETECT
	Blue	Red	0x54	PEI_MEMORY_ERROR
	Blue	Green	0x55	PEI_MEMORY_NOT_INSTALLED
I/O PORT	Yellow	White	0x70	DXE_SB_INIT
	Yellow	Blue	0x97	DXE_CON_OUT_CONNECT
	Yellow	Yellow	0x99	DXE_SIO_INIT
	Yellow	Red	0xD6	DXE_NO_CON_OUT
BOOT	Green	White	0x91	DXE_BDS_CONNECT_DRIVERS
	Green	Blue	0x94	DXE_PCI_BUS_ENUM
	Green	Yellow	0x9A	DXE_USB_BEGIN
	Green	Red	0xDA	DXE_BOOT_OPTION_FAILED
	Green	Green	0xA2	DXE_IDE_DETECT
	Red	Red	0xAB	ENTER BIOS SETUP
	None	None	0xAD	BOOT OS OR SHELL

\*\*\* There are two LEDs on the LAN port. Please refer to the table below for the LAN port LED indications.

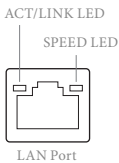

## 2.2 System Top Panel

### 2.2.1 System : iEP-7030E-020, iEP-7031E-020

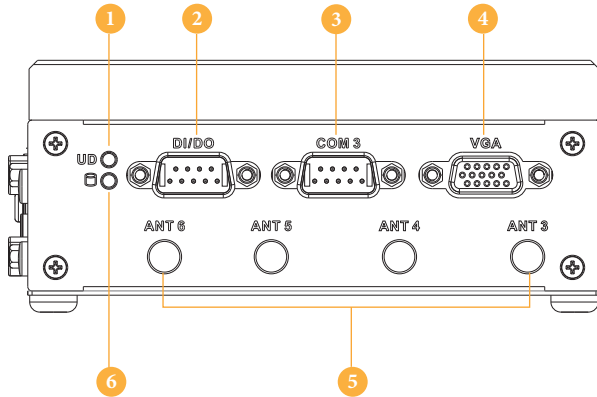

No.	Description																														
1	<b>User Define LED:</b> User define LED indicator behaviors are based on the ASRI API library you use.																														
2	<p><b>GPIO:</b> The 9-pin Digital Input / Output connector allows you to program it for input or output use.</p> <table border="1"> <thead> <tr> <th>Pin</th> <th>Definition</th> <th>Mapping to PCH GPIO Function</th> </tr> </thead> <tbody> <tr> <td>1</td> <td>DIO1</td> <td>GPP_B07</td> </tr> <tr> <td>2</td> <td>DIO3</td> <td>GPP_B15</td> </tr> <tr> <td>3</td> <td>DIO5</td> <td>GPP_D05</td> </tr> <tr> <td>4</td> <td>DIO7</td> <td>GPP_D08</td> </tr> <tr> <td>5</td> <td>GND</td> <td></td> </tr> <tr> <td>6</td> <td>DIO2</td> <td>GPP_B08</td> </tr> <tr> <td>7</td> <td>DIO4</td> <td>GPP_B17</td> </tr> <tr> <td>8</td> <td>DIO6</td> <td>GPP_D07</td> </tr> <tr> <td>9</td> <td>DIO8</td> <td>GPP_D14</td> </tr> </tbody> </table>	Pin	Definition	Mapping to PCH GPIO Function	1	DIO1	GPP_B07	2	DIO3	GPP_B15	3	DIO5	GPP_D05	4	DIO7	GPP_D08	5	GND		6	DIO2	GPP_B08	7	DIO4	GPP_B17	8	DIO6	GPP_D07	9	DIO8	GPP_D14
Pin	Definition	Mapping to PCH GPIO Function																													
1	DIO1	GPP_B07																													
2	DIO3	GPP_B15																													
3	DIO5	GPP_D05																													
4	DIO7	GPP_D08																													
5	GND																														
6	DIO2	GPP_B08																													
7	DIO4	GPP_B17																													
8	DIO6	GPP_D07																													
9	DIO8	GPP_D14																													

3 **Serial (COM3) Port\***: The 9-pin RS232/422/485 serial connector allows you to connect devices that have serial ports.

\* This motherboard supports RS232/422/485 on COM3 port. Please refer to table below for the pin definition. In addition, COM3 port (RS232/422/485) can be adjusted in BIOS setup utility > Advanced Screen > Super IO Configuration. You may refer to our user manual for details.

#### COM3 Port Pin Definition

Pin	RS232	RS422	RS485
1	DCD, Data Carrier Detect	TX-	RTX-
2	RXD, Receive Data	TX+	RTX+
3	TXD, Transmit Data	RX+	NA
4	DTR, Data Terminal Ready	RX-	NA
5	GND	GND	GND
6	DSR, Data Set Ready	NA	NA
7	RTS, Request To Send	NA	NA
8	CTS, Clear To Send	NA	NA
9	NA	NA	NA

4 **VGA:** Use a VGA cable to connect between the system and your monitor.

Pin	Signal	Signal	Pin
1	RED_VGA	NA	9
2	GRN_VGA	GND	10
3	BLU_VGA	NA	11
4	NA	VGA_SDA	12
5	GND	HS_5V	13
6	GND	VS_5V	14
7	GND	VGA_SCL	15
8	GND		

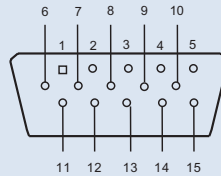

5 **Antennas:** The antenna hole allows you to connect a wireless antenna to enhance wireless signal reception.

6 **Storage LED:** Storage LED indicator behaviors vary depending on the storage module you use.

2.2.2 System : iEP-7030E-021, iEP-7031E-021, iEP-7030E-022, iEP-7031E-022, iEP-7030E-023, iEP-7031E-023

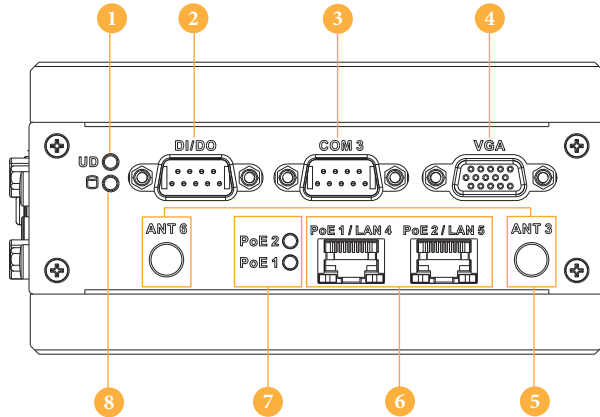

No.	Description
1	<b>User Define LED:</b> User define LED indicator behaviors are based on the ASRI API library you use.
2	<b>GPIO:</b> The 9-pin Digital Input / Output connector allows you to program it for input or output use.

  

Pin	Definition	Mapping to PCH GPIO Function
1	DIO1	GPP_B07
2	DIO3	GPP_B15
3	DIO5	GPP_D05
4	DIO7	GPP_D08
5	GND	
6	DIO2	GPP_B08
7	DIO4	GPP_B17
8	DIO6	GPP_D07
9	DIO8	GPP_D14

  

The diagram shows a 9-pin connector with the following pin definitions:

- 1: DIO1 (marked with a square symbol)
- 2: DIO3
- 3: DIO5
- 4: DIO7
- 5: GND
- 6: DIO2
- 7: DIO4
- 8: DIO6
- 9: DIO8

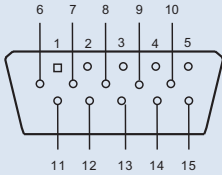
3	<p><b>Serial (COM3) Port*</b>: The 9-pin RS232/422/485 serial connector allows you to connect devices that have serial ports.</p> <p>* This motherboard supports RS232/422/485 on COM3 port. Please refer to table below for the pin definition. In addition, COM3 port (RS232/422/485) can be adjusted in BIOS setup utility &gt; Advanced Screen &gt; Super IO Configuration. You may refer to our user manual for details.</p> <p style="text-align: center;"><b>COM3 Port Pin Definition</b></p> <table border="1"> <thead> <tr> <th>Pin</th> <th>RS232</th> <th>RS422</th> <th>RS485</th> </tr> </thead> <tbody> <tr> <td>1</td> <td>DCD, Data Carrier Detect</td> <td>TX-</td> <td>RTX-</td> </tr> <tr> <td>2</td> <td>RXD, Receive Data</td> <td>TX+</td> <td>RTX+</td> </tr> <tr> <td>3</td> <td>TXD, Transmit Data</td> <td>RX+</td> <td>NA</td> </tr> <tr> <td>4</td> <td>DTR, Data Terminal Ready</td> <td>RX-</td> <td>NA</td> </tr> <tr> <td>5</td> <td>GND</td> <td>GND</td> <td>GND</td> </tr> <tr> <td>6</td> <td>DSR, Data Set Ready</td> <td>NA</td> <td>NA</td> </tr> <tr> <td>7</td> <td>RTS, Request To Send</td> <td>NA</td> <td>NA</td> </tr> <tr> <td>8</td> <td>CTS, Clear To Send</td> <td>NA</td> <td>NA</td> </tr> <tr> <td>9</td> <td>NA</td> <td>NA</td> <td>NA</td> </tr> </tbody> </table>	Pin	RS232	RS422	RS485	1	DCD, Data Carrier Detect	TX-	RTX-	2	RXD, Receive Data	TX+	RTX+	3	TXD, Transmit Data	RX+	NA	4	DTR, Data Terminal Ready	RX-	NA	5	GND	GND	GND	6	DSR, Data Set Ready	NA	NA	7	RTS, Request To Send	NA	NA	8	CTS, Clear To Send	NA	NA	9	NA	NA	NA
Pin	RS232	RS422	RS485																																						
1	DCD, Data Carrier Detect	TX-	RTX-																																						
2	RXD, Receive Data	TX+	RTX+																																						
3	TXD, Transmit Data	RX+	NA																																						
4	DTR, Data Terminal Ready	RX-	NA																																						
5	GND	GND	GND																																						
6	DSR, Data Set Ready	NA	NA																																						
7	RTS, Request To Send	NA	NA																																						
8	CTS, Clear To Send	NA	NA																																						
9	NA	NA	NA																																						
4	<p><b>VGA:</b> Use a VGA cable to connect between the system and your monitor.</p> <table border="1"> <thead> <tr> <th>Pin</th> <th>Signal</th> <th>Signal</th> <th>Pin</th> </tr> </thead> <tbody> <tr> <td>1</td> <td>RED_VGA</td> <td>NA</td> <td>9</td> </tr> <tr> <td>2</td> <td>GRN_VGA</td> <td>GND</td> <td>10</td> </tr> <tr> <td>3</td> <td>BLU_VGA</td> <td>NA</td> <td>11</td> </tr> <tr> <td>4</td> <td>NA</td> <td>VGA_SDA</td> <td>12</td> </tr> <tr> <td>5</td> <td>GND</td> <td>HS_5V</td> <td>13</td> </tr> <tr> <td>6</td> <td>GND</td> <td>VS_5V</td> <td>14</td> </tr> <tr> <td>7</td> <td>GND</td> <td>VGA_SCL</td> <td>15</td> </tr> <tr> <td>8</td> <td>GND</td> <td></td> <td></td> </tr> </tbody> </table> 	Pin	Signal	Signal	Pin	1	RED_VGA	NA	9	2	GRN_VGA	GND	10	3	BLU_VGA	NA	11	4	NA	VGA_SDA	12	5	GND	HS_5V	13	6	GND	VS_5V	14	7	GND	VGA_SCL	15	8	GND						
Pin	Signal	Signal	Pin																																						
1	RED_VGA	NA	9																																						
2	GRN_VGA	GND	10																																						
3	BLU_VGA	NA	11																																						
4	NA	VGA_SDA	12																																						
5	GND	HS_5V	13																																						
6	GND	VS_5V	14																																						
7	GND	VGA_SCL	15																																						
8	GND																																								
5	<p><b>Antennas:</b> The antenna hole allows you to connect a wireless antenna to enhance wireless signal reception.</p>																																								
6	<p><b>LAN ports**:</b> The RJ45 8P8C LAN ports support a standard Ethernet cable for connection to local network, and support PoE, is capable of bridging, and can perform auto-negotiation.</p> <p>*However, these features require an operating system to be activated.</p>																																								
7	<p><b>PoE LEDs:</b> This indicator lights up when your system is connected to PoE1/PoE2.</p>																																								
8	<p><b>Storage LED:</b> Storage LED indicator behaviors vary depending on the storage module you use.</p>																																								

\*\* There are two LEDs on the LAN port. Please refer to the table below for the LAN port LED indications.

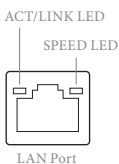

## 2.2.3 System : iEP-7030E-024, iEP-7031E-024

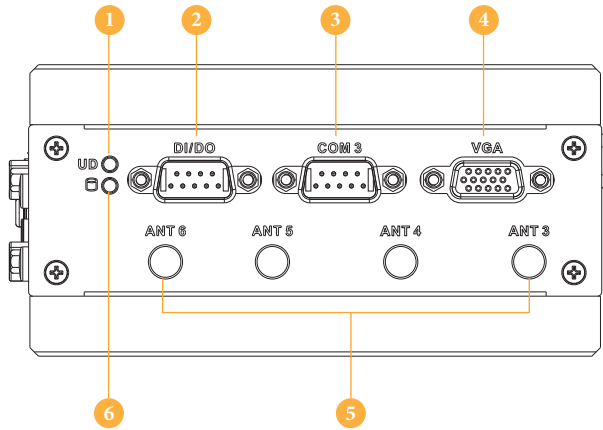

No.	Description
1	<b>User Define LED:</b> User define LED indicator behaviors are based on the ASRI API library you use.
2	<b>GPIO:</b> The 9-pin Digital Input / Output connector allows you to program it for input or output use.

Pin	Definition	Mapping to PCH GPIO Function
1	DIO1	GPP_B07
2	DIO3	GPP_B15
3	DIO5	GPP_D05
4	DIO7	GPP_D08
5	GND	
6	DIO2	GPP_B08
7	DIO4	GPP_B17
8	DIO6	GPP_D07
9	DIO8	GPP_D14

3	<p><b>Serial (COM3) Port*:</b> The 9-pin RS232/422/485 serial connector allows you to connect devices that have serial ports.</p> <p>* This motherboard supports RS232/422/485 on COM3 port. Please refer to table below for the pin definition. In addition, COM3 port (RS232/422/485) can be adjusted in BIOS setup utility &gt; Advanced Screen &gt; Super IO Configuration. You may refer to our user manual for details.</p> <p style="text-align: center;"><b>COM3 Port Pin Definition</b></p> <table border="1" data-bbox="224 341 838 555"> <thead> <tr> <th>Pin</th> <th>RS232</th> <th>RS422</th> <th>RS485</th> </tr> </thead> <tbody> <tr> <td>1</td> <td>DCD, Data Carrier Detect</td> <td>TX-</td> <td>RTX-</td> </tr> <tr> <td>2</td> <td>RXD, Receive Data</td> <td>TX+</td> <td>RTX+</td> </tr> <tr> <td>3</td> <td>TXD, Transmit Data</td> <td>RX+</td> <td>NA</td> </tr> <tr> <td>4</td> <td>DTR, Data Terminal Ready</td> <td>RX-</td> <td>NA</td> </tr> <tr> <td>5</td> <td>GND</td> <td>GND</td> <td>GND</td> </tr> <tr> <td>6</td> <td>DSR, Data Set Ready</td> <td>NA</td> <td>NA</td> </tr> <tr> <td>7</td> <td>RTS, Request To Send</td> <td>NA</td> <td>NA</td> </tr> <tr> <td>8</td> <td>CTS, Clear To Send</td> <td>NA</td> <td>NA</td> </tr> <tr> <td>9</td> <td>NA</td> <td>NA</td> <td>NA</td> </tr> </tbody> </table>	Pin	RS232	RS422	RS485	1	DCD, Data Carrier Detect	TX-	RTX-	2	RXD, Receive Data	TX+	RTX+	3	TXD, Transmit Data	RX+	NA	4	DTR, Data Terminal Ready	RX-	NA	5	GND	GND	GND	6	DSR, Data Set Ready	NA	NA	7	RTS, Request To Send	NA	NA	8	CTS, Clear To Send	NA	NA	9	NA	NA	NA
Pin	RS232	RS422	RS485																																						
1	DCD, Data Carrier Detect	TX-	RTX-																																						
2	RXD, Receive Data	TX+	RTX+																																						
3	TXD, Transmit Data	RX+	NA																																						
4	DTR, Data Terminal Ready	RX-	NA																																						
5	GND	GND	GND																																						
6	DSR, Data Set Ready	NA	NA																																						
7	RTS, Request To Send	NA	NA																																						
8	CTS, Clear To Send	NA	NA																																						
9	NA	NA	NA																																						
4	<p><b>VGA:</b> Use a VGA cable to connect between the system and your monitor.</p> <table border="1" data-bbox="240 644 538 836"> <thead> <tr> <th>Pin</th> <th>Signal</th> <th>Signal</th> <th>Pin</th> </tr> </thead> <tbody> <tr> <td>1</td> <td>RED_VGA</td> <td>NA</td> <td>9</td> </tr> <tr> <td>2</td> <td>GRN_VGA</td> <td>GND</td> <td>10</td> </tr> <tr> <td>3</td> <td>BLU_VGA</td> <td>NA</td> <td>11</td> </tr> <tr> <td>4</td> <td>NA</td> <td>VGA_SDA</td> <td>12</td> </tr> <tr> <td>5</td> <td>GND</td> <td>HS_5V</td> <td>13</td> </tr> <tr> <td>6</td> <td>GND</td> <td>VS_5V</td> <td>14</td> </tr> <tr> <td>7</td> <td>GND</td> <td>VGA_SCL</td> <td>15</td> </tr> <tr> <td>8</td> <td>GND</td> <td></td> <td></td> </tr> </tbody> </table> 	Pin	Signal	Signal	Pin	1	RED_VGA	NA	9	2	GRN_VGA	GND	10	3	BLU_VGA	NA	11	4	NA	VGA_SDA	12	5	GND	HS_5V	13	6	GND	VS_5V	14	7	GND	VGA_SCL	15	8	GND						
Pin	Signal	Signal	Pin																																						
1	RED_VGA	NA	9																																						
2	GRN_VGA	GND	10																																						
3	BLU_VGA	NA	11																																						
4	NA	VGA_SDA	12																																						
5	GND	HS_5V	13																																						
6	GND	VS_5V	14																																						
7	GND	VGA_SCL	15																																						
8	GND																																								
5	<p><b>Antennas:</b> The antenna hole allows you to connect a wireless antenna to enhance wireless signal reception.</p>																																								
6	<p><b>Storage LED:</b> Storage LED indicator behaviors vary depending on the storage module you use.</p>																																								

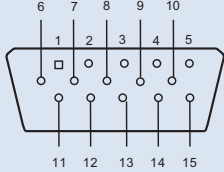
## 2.2.4 System : iEP-7030E-025, iEP-7031E-025

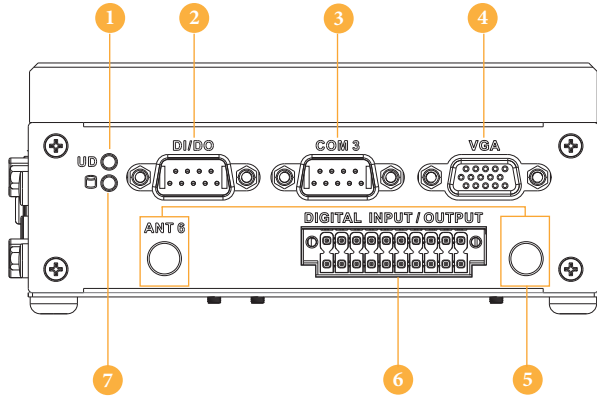

No.	Description
1	<b>User Define LED:</b> User define LED indicator behaviors are based on the ASRI API library you use.
2	<b>GPIO:</b> The 9-pin Digital Input / Output connector allows you to program it for input or output use.

Pin	Definition	Mapping to PCH GPIO Function
1	DIO1	GPP_B07
2	DIO3	GPP_B15
3	DIO5	GPP_D05
4	DIO7	GPP_D08
5	GND	
6	DIO2	GPP_B08
7	DIO4	GPP_B17
8	DIO6	GPP_D07
9	DIO8	GPP_D14

3	<p><b>Serial (COM3) Port*:</b> The 9-pin RS232/422/485 serial connector allows you to connect devices that have serial ports.</p> <p>* This motherboard supports RS232/422/485 on COM3 port. Please refer to table below for the pin definition. In addition, COM3 port (RS232/422/485) can be adjusted in BIOS setup utility &gt; Advanced Screen &gt; Super IO Configuration. You may refer to our user manual for details.</p> <p style="text-align: center;"><b>COM3 Port Pin Definition</b></p> <table border="1" style="width: 100%; border-collapse: collapse;"> <thead> <tr> <th>Pin</th> <th>RS232</th> <th>RS422</th> <th>RS485</th> </tr> </thead> <tbody> <tr> <td>1</td> <td>DCD, Data Carrier Detect</td> <td>TX-</td> <td>RTX-</td> </tr> <tr> <td>2</td> <td>RXD, Receive Data</td> <td>TX+</td> <td>RTX+</td> </tr> <tr> <td>3</td> <td>TXD, Transmit Data</td> <td>RX+</td> <td>NA</td> </tr> <tr> <td>4</td> <td>DTR, Data Terminal Ready</td> <td>RX-</td> <td>NA</td> </tr> <tr> <td>5</td> <td>GND</td> <td>GND</td> <td>GND</td> </tr> <tr> <td>6</td> <td>DSR, Data Set Ready</td> <td>NA</td> <td>NA</td> </tr> <tr> <td>7</td> <td>RTS, Request To Send</td> <td>NA</td> <td>NA</td> </tr> <tr> <td>8</td> <td>CTS, Clear To Send</td> <td>NA</td> <td>NA</td> </tr> <tr> <td>9</td> <td>NA</td> <td>NA</td> <td>NA</td> </tr> </tbody> </table>	Pin	RS232	RS422	RS485	1	DCD, Data Carrier Detect	TX-	RTX-	2	RXD, Receive Data	TX+	RTX+	3	TXD, Transmit Data	RX+	NA	4	DTR, Data Terminal Ready	RX-	NA	5	GND	GND	GND	6	DSR, Data Set Ready	NA	NA	7	RTS, Request To Send	NA	NA	8	CTS, Clear To Send	NA	NA	9	NA	NA	NA				
Pin	RS232	RS422	RS485																																										
1	DCD, Data Carrier Detect	TX-	RTX-																																										
2	RXD, Receive Data	TX+	RTX+																																										
3	TXD, Transmit Data	RX+	NA																																										
4	DTR, Data Terminal Ready	RX-	NA																																										
5	GND	GND	GND																																										
6	DSR, Data Set Ready	NA	NA																																										
7	RTS, Request To Send	NA	NA																																										
8	CTS, Clear To Send	NA	NA																																										
9	NA	NA	NA																																										
4	<p><b>VGA:</b> Use a VGA cable to connect between the system and your monitor.</p> <table border="1" style="width: 50%; border-collapse: collapse;"> <thead> <tr> <th>Pin</th> <th>Signal</th> <th>Signal</th> <th>Pin</th> </tr> </thead> <tbody> <tr> <td>1</td> <td>RED_VGA</td> <td>NA</td> <td>9</td> </tr> <tr> <td>2</td> <td>GRN_VGA</td> <td>GND</td> <td>10</td> </tr> <tr> <td>3</td> <td>BLU_VGA</td> <td>NA</td> <td>11</td> </tr> <tr> <td>4</td> <td>NA</td> <td>VGA_SDA</td> <td>12</td> </tr> <tr> <td>5</td> <td>GND</td> <td>HS_5V</td> <td>13</td> </tr> <tr> <td>6</td> <td>GND</td> <td>VS_5V</td> <td>14</td> </tr> <tr> <td>7</td> <td>GND</td> <td>VGA_SCL</td> <td>15</td> </tr> <tr> <td>8</td> <td>GND</td> <td></td> <td></td> </tr> </tbody> </table> 	Pin	Signal	Signal	Pin	1	RED_VGA	NA	9	2	GRN_VGA	GND	10	3	BLU_VGA	NA	11	4	NA	VGA_SDA	12	5	GND	HS_5V	13	6	GND	VS_5V	14	7	GND	VGA_SCL	15	8	GND										
Pin	Signal	Signal	Pin																																										
1	RED_VGA	NA	9																																										
2	GRN_VGA	GND	10																																										
3	BLU_VGA	NA	11																																										
4	NA	VGA_SDA	12																																										
5	GND	HS_5V	13																																										
6	GND	VS_5V	14																																										
7	GND	VGA_SCL	15																																										
8	GND																																												
5	<p><b>Antennas:</b> The antenna hole allows you to connect a wireless antenna to enhance wireless signal reception.</p>																																												
6	<p><b>Digital I/O:</b> This system provides sink/source isolation 36V circuits for the customer's device.</p> <table border="1" style="width: 100%; border-collapse: collapse;"> <thead> <tr> <th>Pin</th> <th>Signal</th> <th>Signal</th> <th>Pin</th> </tr> </thead> <tbody> <tr> <td>1</td> <td>GND</td> <td>GND</td> <td>2</td> </tr> <tr> <td>3</td> <td>MCU_SPI0_MOSI</td> <td>GPP_E16</td> <td>4</td> </tr> <tr> <td>5</td> <td>MCU_SPI0_MISO</td> <td>GPP_E7</td> <td>6</td> </tr> <tr> <td>7</td> <td>MCU_SPI0_CLK</td> <td>GPP_E3</td> <td>8</td> </tr> <tr> <td>9</td> <td>MCU_SPI0_SS</td> <td>GPP_D3</td> <td>10</td> </tr> <tr> <td>11</td> <td>GPP_A15</td> <td>GPP_E13</td> <td>12</td> </tr> <tr> <td>13</td> <td>GPP_A14</td> <td>GPP_E2</td> <td>14</td> </tr> <tr> <td>15</td> <td>ICE_CLK</td> <td>GPP_E1</td> <td>16</td> </tr> <tr> <td>17</td> <td>ICE_DAT</td> <td>GPP_B15</td> <td>18</td> </tr> <tr> <td>19</td> <td>+3V</td> <td>+3V</td> <td>20</td> </tr> </tbody> </table> 	Pin	Signal	Signal	Pin	1	GND	GND	2	3	MCU_SPI0_MOSI	GPP_E16	4	5	MCU_SPI0_MISO	GPP_E7	6	7	MCU_SPI0_CLK	GPP_E3	8	9	MCU_SPI0_SS	GPP_D3	10	11	GPP_A15	GPP_E13	12	13	GPP_A14	GPP_E2	14	15	ICE_CLK	GPP_E1	16	17	ICE_DAT	GPP_B15	18	19	+3V	+3V	20
Pin	Signal	Signal	Pin																																										
1	GND	GND	2																																										
3	MCU_SPI0_MOSI	GPP_E16	4																																										
5	MCU_SPI0_MISO	GPP_E7	6																																										
7	MCU_SPI0_CLK	GPP_E3	8																																										
9	MCU_SPI0_SS	GPP_D3	10																																										
11	GPP_A15	GPP_E13	12																																										
13	GPP_A14	GPP_E2	14																																										
15	ICE_CLK	GPP_E1	16																																										
17	ICE_DAT	GPP_B15	18																																										
19	+3V	+3V	20																																										
7	<p><b>Storage LED:</b> Storage LED indicator behaviors vary depending on the storage module you use.</p>																																												

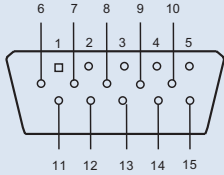
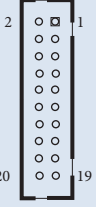
## 2.3 Inside View

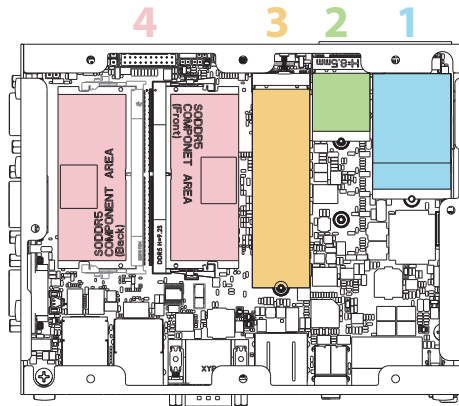

No.	Description
1	<b>M.2 Slot (B Key):</b> The M.2 slot allows you to install 3042/3052 4G LTE/5G module.
2	<b>M.2 Slot (E Key):</b> The M.2 slot allows you to install 2230 Wi-Fi/BT module and 2230/2260 2-LAN Port module.
3	<b>M.2 Slot (M Key):</b> The M.2 slot allows you to install 2280 M.2 devices.
4	<b>Memory:</b> Dual Small Outline Dual Inline Memory module slots are designed for DDR5 memory modules



*SO-DIMM memory, hard drive and M.2 SSD are not included with this system.*

## 2.4 Rear View

- For Basic/8DIO SKU

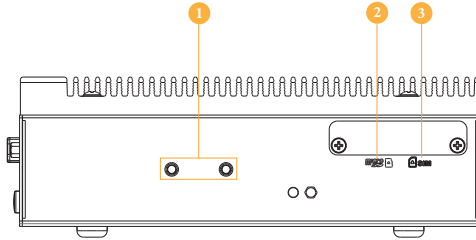

- For PoE/5LAN/5G SKU

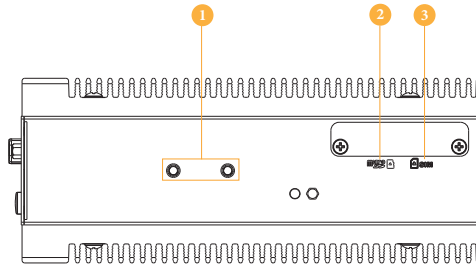

No.	Description
1	<b>Mounting Holes:</b> The holes support Wall Mount and DIN Rail brackets for system in vertical position.
2	<b>Micro SD Slot:</b> The slot supports Micro SD card.
3	<b>SIM Card Slot:</b> The SIM Card slot allows you to install a Nano type SIM card.

## 2.5 Right View (System : iEP-7030E-020, iEP-7031E-020, iEP-7030E-025, iEP-7031E-025)

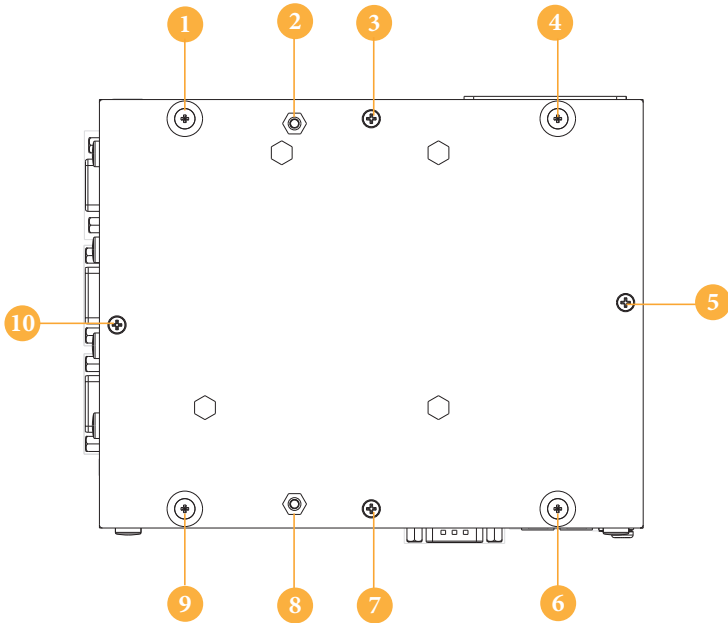

No.	Description
1, 4, 6, 9	<b>Mounting Holes:</b> The holes support Wall Mount brackets for system in vertical position.
2, 8	<b>VESA Holes:</b> The holes support VESA bracket to attach the iEP-703XE-020 and iEP-703XE-025 to the rear of a compatible display.
3, 5, 7, 10	<b>Front Cover screw Holes:</b> The holes are used to secure the front cover.

## 2.6 Position

The system should be placed in vertical or horizontal position.

- Positions of the iEP-7030E-020, iEP-7031E-020, iEP-7030E-025 and iEP-7031E-025: vertical & horizontal

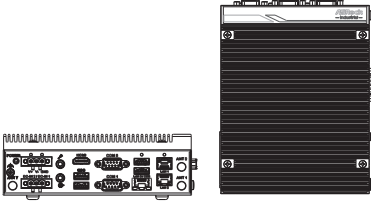

- Positions of the iEP-7030E-021, iEP-7031E-021, iEP-7030E-022, iEP-7031E-022, iEP-7030E-023, iEP-7031E-023, iEP-7030E-024 and iEP-7031E-024: only vertical

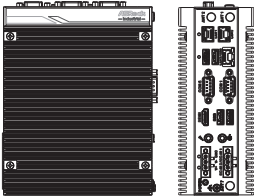

# Chapter 3 Hardware Installation

This chapter helps you install or remove important components.

## 3.1 How to Install the Wi-Fi Module (2230) to the M.2 Key E Slot (Optional)

1. Locate the WiFi Module slot on the motherboard.

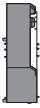

2. Carefully insert the WiFi Module into the slot at a 30-degree angle.

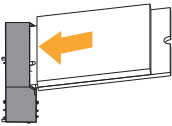

3. Tighten the screw to secure the WiFi Module to the motherboard.

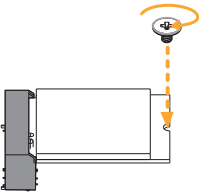

4. Paste the thermal pad onto the WiFi Module. Then remove the membrane.

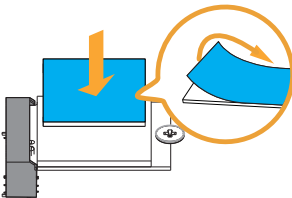

5. Remove the antenna rubber on the box cover.

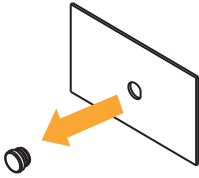

6. Attach the SMA cable and washer to both sides of the cover, and secure them with the nut.

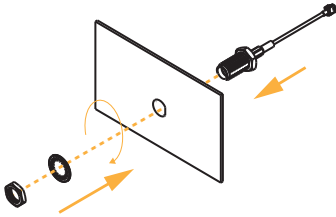

7. Install the Wifi antenna onto the SMA cable.

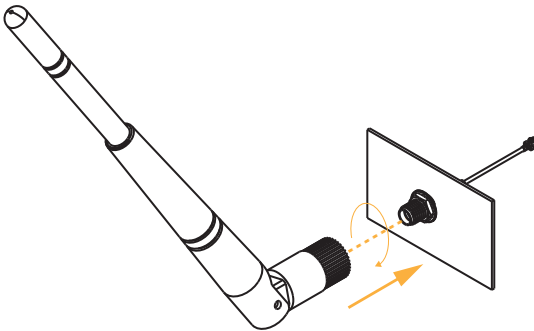

## 3.2 How to Install the 4G LTE/5G Module (3042/3052) to the M.2 Key B Slot (Optional)

1. Locate the 4G LTE/5G Module slot on the motherboard.

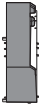

2. Carefully insert the 4G LTE/5G Module into the slot at a 30-degree angle.

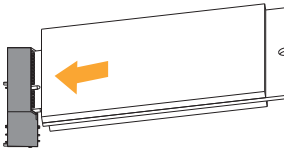

3. Tighten the screw to secure the 4G LTE/5G Module to the motherboard.



4. Paste the thermal pad onto the 4G LTE/5G Module. Then remove the membrane.

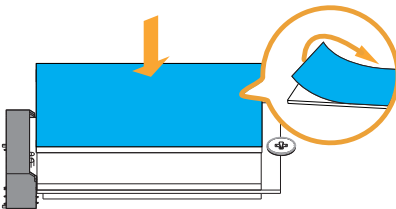

5. Remove the antenna rubber on the box cover.

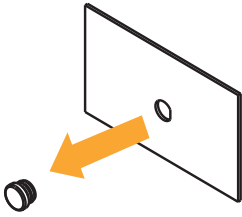

6. Attach the SMA cable and washer to both sides of the cover, and secure them with the nut.

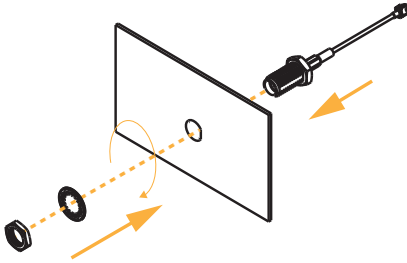

7. Install the 4G LTE/5G antenna onto the SMA cable.

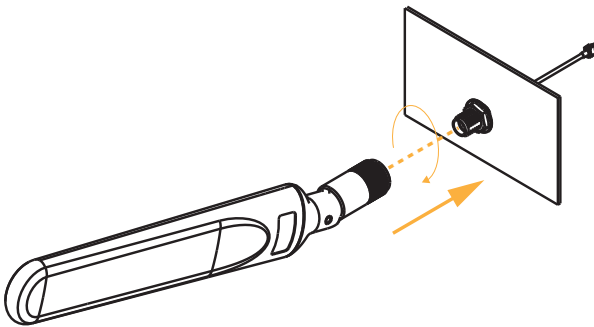

### 3.3 How to Install the M.2 SSD (2280) to the M.2 Key M Socket

1. Locate the M.2 slot on the motherboard.

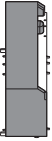

2. Carefully insert the M.2 SSD (Type 2280) into the slot at a 30-degree angle.

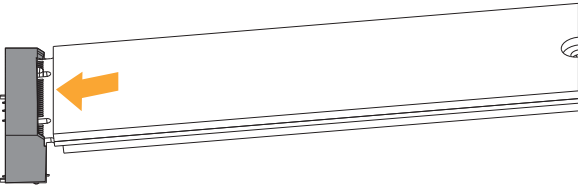

3. Tighten the screw to secure the M.2 SSD (Type 2280) to the motherboard.



## 3.4 How to Install the Memory Modules



The iEP-7030E Series requires DDR5 SO-DIMM (1.1V).  
For dual channel configuration, you always need to install identical (the same brand, speed, size and chip-type) DDR5 SO-DIMM pairs



The SO-DIMM only fits in one correct orientation. It will cause permanent damage to the motherboard and the DIMM if you force the DIMM into the slot at incorrect orientation.

1. Carefully insert the SO-DIMM memory modules into the slot at a 30-degree angle..

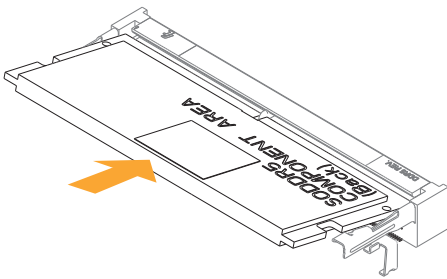

2. Push down until the modules snap into place.

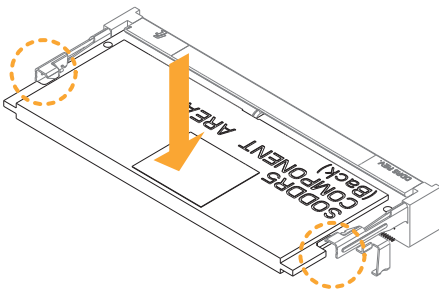

### 3.5 How to Install a Nano SIM Card and Micro SD Card

1. Release the screws on the iEP-7030E Series and remove the SIM/Micro SD Card slot cover.

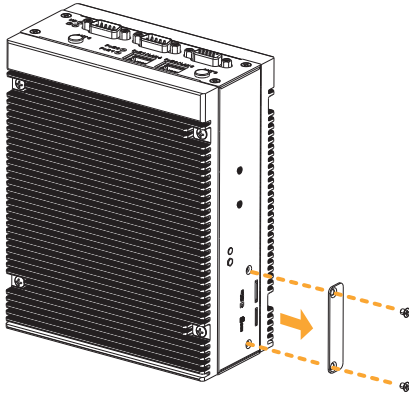

2. With the gold contacts facing front, carefully insert the SIM Card or the SD Card into the designated slot until it clicks.

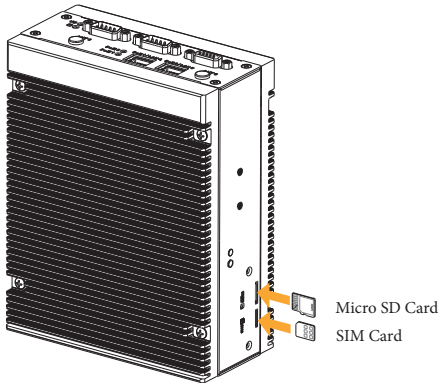

3. Place the cover back and secure it to the iEP-7030E Series with screws.

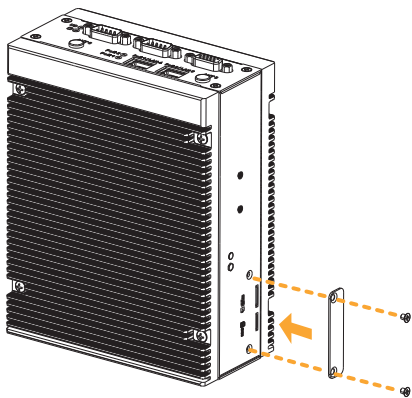

### 3.6 How to Install the Wall Mounting Bracket (Optional)

- Wall mounting: vertical
1. Attach the wall mounting brackets to the iEP-7030E Series and secure it with two screws. Then you can attach the iEP-7030E Series to the wall with four screws.

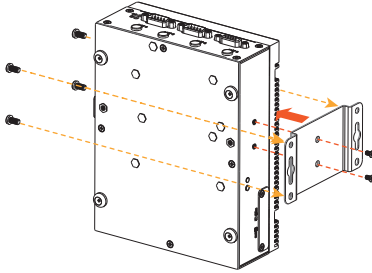

2. The wall mounting bracket is installed.

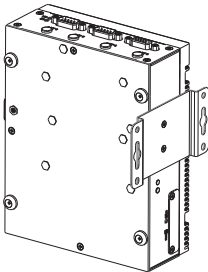

Dimension of the iEP-7030E Series  
with Wall Mounting Bracket Installed

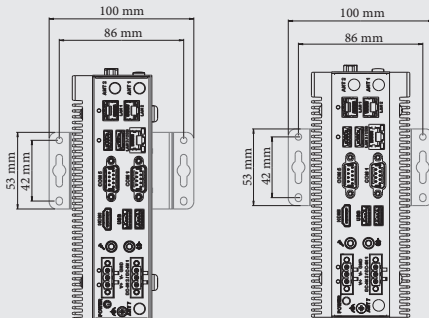

- Wall mounting: horizontal
1. Attach the wall mounting brackets to the iEP-7030E-020, iEP-7031E-020, iEP-7030E-025, iEP-7031E-025 and secure it with screws.

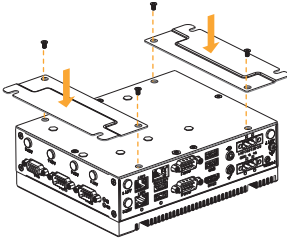

2. The wall mounting brackets are installed.

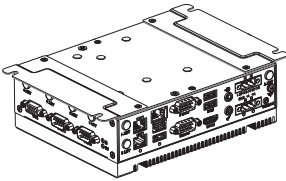

Dimension of the iEP-7030E-020, iEP-7031E-020,  
iEP-7030E-025, iEP-7031E-025  
with Wall Mounting Bracket Installed

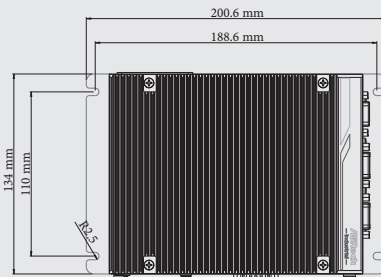

*Wall Mounting Bracket is not provided by default. Please purchase it separately if needed.*

### 3.7 How to Install VESA Bracket (Optional) (for Basic/8DIO SKU)

1. Attach the two screws to the base of the iEP-7030E-020, iEP-7031E-020, iEP-7030E-025, iEP-7031E-025.

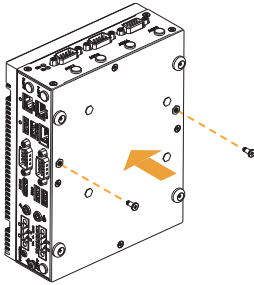

2. Attach the VESA Bracket to the rear of a compatible display using the four screws.  
\*Choose mounting holes depending on the mounting hole pattern of your LCD screen (75 mm × 75 mm or 100 mm × 100 mm).

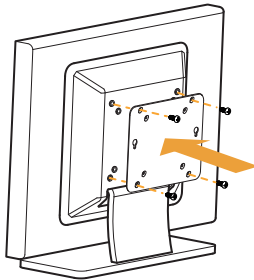

3. Mount the iEP-7030E-020, iEP-7031E-020, iEP-7030E-025, iEP-7031E-025 by sliding it into place.

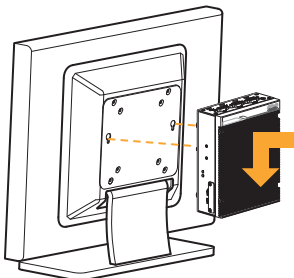

### 3.8 How to Install the Din Rail (Optional)

1. Attach the Din Rail Bracket to the iEP-7030E Series and secure it with screws.

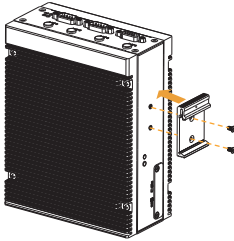

iEP-7030E-021, iEP-7031E-021,  
iEP-7030E-022, iEP-7031E-022,  
iEP-7030E-023, iEP-7031E-023,  
iEP-7030E-024, iEP-7031E-024

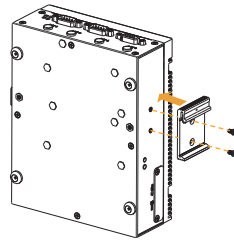

iEP-7030E-020, iEP-7031E-020,  
iEP-7030E-025, iEP-7031E-025

2. Then you can place the iEP-7030E Series to the Din Rail.

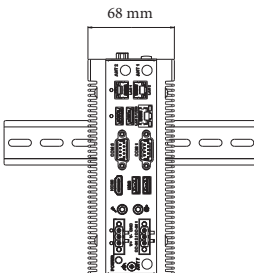

iEP-7030E-021, iEP-7031E-021,  
iEP-7030E-022, iEP-7031E-022,  
iEP-7030E-023, iEP-7031E-023,  
iEP-7030E-024, iEP-7031E-024

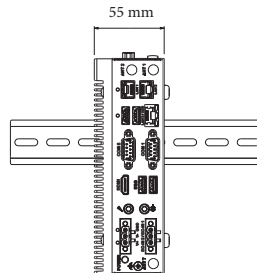

iEP-7030E-020, iEP-7031E-020,  
iEP-7030E-025, iEP-7031E-025



*Din Rail Bracket is not provided by default. Please purchase it separately if needed.*

### 3.9 How to Remove the Membranes

Please note to remove the membranes from the heatsinks before reinstall the bottom case.

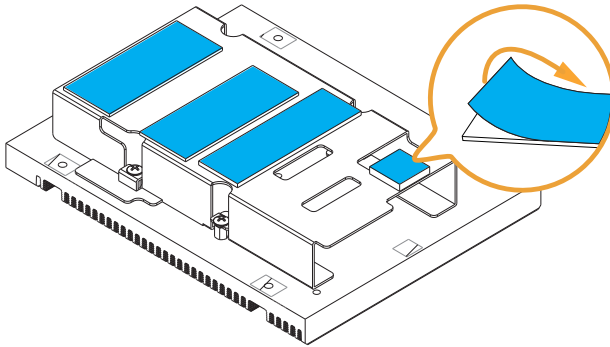

### 3.10 How to Install Phoenix Connector and the Adapter (Optional)

1. Insert white (+) cable of the adapter into the left port of the phoenix connector, and insert the black (-) cable into the middle port. Ensure the cables are inserted to the end.

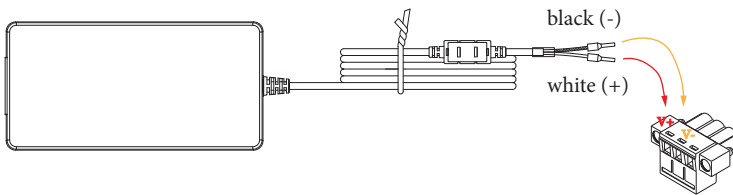

2. Tighten the left two screws from the top of the phoenix connector with a flathead screwdriver. Ensure the cables are inserted to the end and cannot be unplugged.

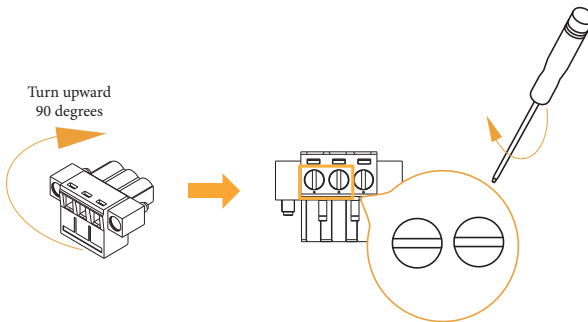

# Chapter 4 Motherboard

## 4.1 Motherboard Layout

Top Side :

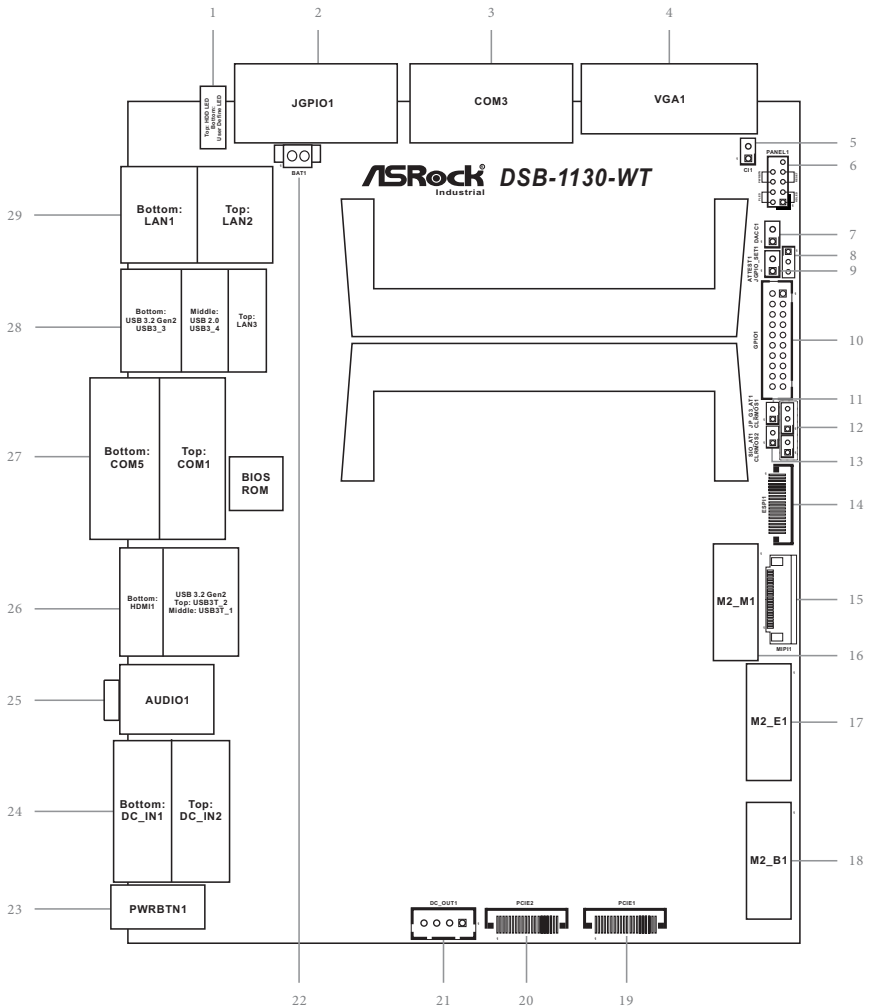

**Rear Side :**

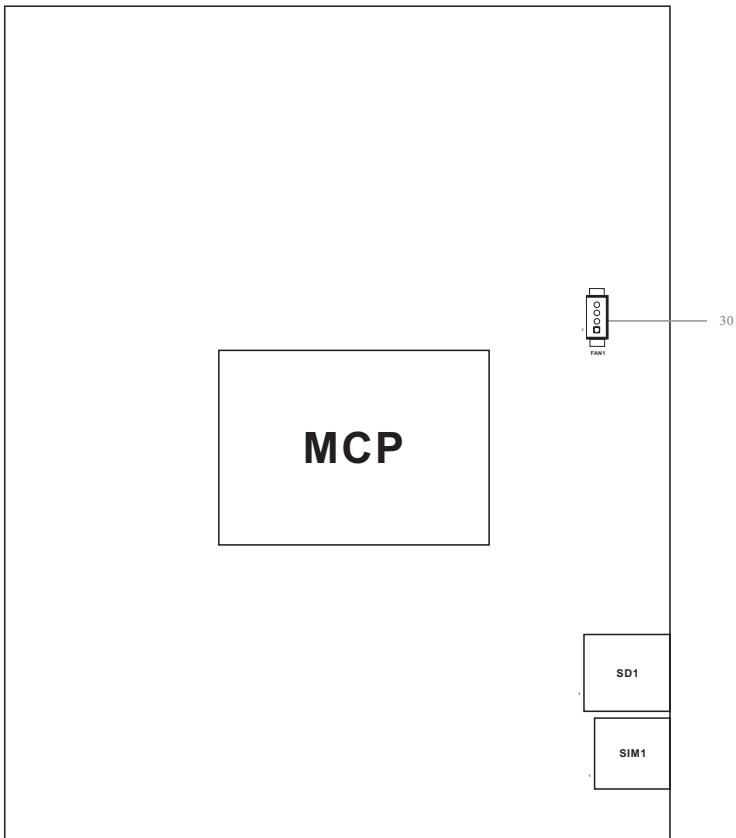

- 1 : Top: HDD LED  
Bottom: User Define LED
  - 2 : Digital Input/Output Connector (JGPIO1)
  - 3 : COM Port (COM3) (RS232/422/485)\*
  - 4 : D-Sub Port (VGA1)
  - 5 : Chassis Intrusion Headers (CI1)
  - 6 : System Panel Header (PANEL1)
  - 7 : DACC Jumper (DACC1)
  - 8 : Digital Input/Output Default Value Setting (JGPIO\_SET1)
  - 9 : ATTEST1
  - 10 : Digital Input/Output Connector (GPIO1)
  - 11 : ASRI internal G3 aging jumper (JP\_G3\_AT1)
  - 12 : Clear CMOS Headers (CLRMOS1, CLRMOS2)
  - 13 : ATX/AT Mode Jumper (SIO\_AT1)
  - 14 : ESPI Header (ESPI1)
  - 15 : MIPI Header (MIPI1)
  - 16 : M.2 Key-M Socket (M2\_M1)
  - 17 : M.2 Key-E Socket (M2\_E1)
  - 18 : M.2 Key-B Socket (M2\_B1)
  - 19 : PCIE Connector (PCIE1)
  - 20 : PCIE Connector (PCIE2)
  - 21 : Power Connector (DC\_OUT1) (12V/GND)
  - 22 : Battery Connector (BAT1)
  - 23 : Power Button (PWRBTN1)
  - 24 : DC Input Connectors (DC\_IN1\_2)  
Top : DC\_IN2  
Bottom : DC\_IN1
  - 25 : Audio Jacks  
Top : Green - Line Out  
Bottom : Pink - Mic In
  - 26 : USB 3.2 Gen2 Ports  
Top : USB3T\_2  
Middle : USB3T\_1  
Bottom : HDMI Port (HDMI1)
  - 27 : COM Ports  
Top: COM1 (RS232/422/485)\*  
Bottom: COM5 (RS232/422/485)\*
  - 28 : Top : RJ45 LAN Port (LAN3)  
Middle : USB 2.0 Port (USB3\_4)  
Bottom : USB 3.2 Gen2 Port (USB3\_3)
  - 29 : RJ45 LAN Ports  
Top : LAN2  
Bottom : LAN1
- Backside:
- 30 : Fan Connector (FAN1)

## 4.2 Jumpers Setup

The illustration shows how jumpers are setup. When the jumper cap is placed on pins, the jumper is “Short.” If no jumper cap is placed on pins, the jumper is “Open.” The illustration shows a 3-pin jumper whose pin1 and pin2 are “Short” when a jumper cap is placed on these 2 pins.

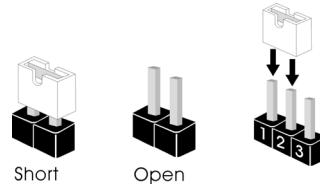

### Chassis Intrusion Header

(2-pin CI1)

(see p. 50, No. 5)



Setting	Description
Close	Active Case Open
Open	Normal (Default)

This motherboard supports CASE OPEN detection feature that detects if the chassis cover has been removed. This feature requires a chassis with chassis intrusion detection design.

### DACC Jumper

(2-pin DACC1)

(see p. 50, No. 7)



Setting	Description
Open	No ACC
Short	ACC (Default)

Auto clear CMOS when system boot improperly.

### Digital Input/Output Default Value Setting

(3-pin JGPIO\_SET1)

(see p. 50, No. 8)



Setting	Description
1-2	Pull-High (Default)
2-3	Pull-Low

### ATTEST1

(2-pin ATTEST1)

(see p. 50, No. 9)



For internal test.

### ASRI internal G3 aging jumper

(2-pin JP\_G3\_AT1)

(see p. 50, No. 11)



Pin	Description
1	G3_AT_GPIO#
2	GND

### Clear CMOS Jumpers

(3-pin CLRMOS1)

(see p. 50, No. 12)



Setting	Description
1-2	Normal (Default)
2-3	Clear CMOS

Note: CLRMOS1 allows you to clear the data in CMOS. To clear and reset the system parameters to default setup, please turn off the computer and unplug the power cord from the power supply. After waiting for 15 seconds, use a jumper cap to short pin2 and pin3 on CLRMOS1 for 5 seconds. However, please do not clear the CMOS right after you update the BIOS. If you need to clear the CMOS when you just finish updating the BIOS, you must boot up the system first, and then shut it down before you do the clear-CMOS action. Please be noted that the date, time and user default profile will be cleared only if the CMOS battery is removed.

(2-pin CLRMOS2)

(see p. 50, No. 12)



Setting	Description
Open	Normal (Default)
Short	Auto Clear CMOS (Power Off)

Note: CLRMOS2 allows you to clear the data in CMOS automatically when AC power on. The data in CMOS includes system setup information such as system password, date, time, and system setup parameters. To clear and reset the system parameters to default setup, please turn off the computer and unplug the power cord, and then use a jumper cap to short the pins on CLRMOS2.

### ATX/AT Mode Jumper

(2-pin SIO\_AT1)

(see p. 50, No. 13)



Setting	Description
Open	ATX Mode (Default)
Short	AT Mode

The header provides auto boot function when AC power is on. If you need the function, short SIO\_AT1 pin 1 and pin 2.

## 4.3 Onboard Headers and Connectors



Onboard headers and connectors are NOT jumpers. Do NOT place jumper caps over these headers and connectors. Placing jumper caps over the headers and connectors will cause permanent damage to the motherboard!

### System Panel Header

(9-pin PANEL1)

(see p. 50, No. 6)

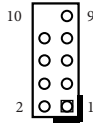

Pin	Signal Name	Signal Name	Pin
1	HDLED+	PLED+	2
3	HDLED-	PLED-	4
5	GND	PWRBTN#	6
7	RESET#	GND	8
9	GND		10

This header accommodates several system front panel functions.



Connect the power switch, reset switch and system status indicator on the chassis to this header according to the pin assignments below. Note the positive and negative pins before connecting the cables.

#### **PWRBTN (Power Switch):**

Connect to the power switch on the chassis front panel. You may configure the way to turn off your system using the power switch.

#### **RESET (Reset Switch):**

Connect to the reset switch on the chassis front panel. Press the reset switch to restart the computer if the computer freezes and fails to perform a normal restart.

#### **PLED (System Power LED):**

Connect to the power status indicator on the chassis front panel. The LED is on when the system is operating. The LED keeps blinking when the system is in S1 sleep state. The LED is off when the system is in S3/S4 sleep state or powered off (S5).

#### **HDLED (Hard Drive Activity LED):**

Connect to the hard drive activity LED on the chassis front panel. The LED is on when the hard drive is reading or writing data.

The front panel design may differ by chassis. A front panel module mainly consists of power switch, reset switch, power LED, hard drive activity LED, speaker and etc. When connecting your chassis front panel module to this header, make sure the wire assignments and the pin assignments are matched correctly.

### Digital Input/Output Connector

(20-pin GPIO1)

(see p. 50, No. 10)

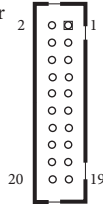

Pin	Signal Name	Signal Name	Pin
1	GND	GND	2
3	MCU_SPI0_MOSI	GPP_E7	4
5	MCU_SPI0_MISO	GPP_E5	6
7	MCU_SPI0_CLK	GPP_E4	8
9	MCU_SPI0_SS	GPP_D3	10
11	DSC_DIO_GP2	GPP_C23	12
13	DSC_DIO_GP1	GPP_C22	14
15	ICE_CLK	GPP_B23	16
17	ICE_DAT	GPP_B20	18
19	+3V	+3V	20

### ESPI Header

(20-pin ESPI1)

(see p. 50, No. 14)



Pin	Signal Name
1	GND
2	C_ESPI_CLK
3	GND
4	C_ESPI_CS#
5	DEBUG_RESET
6	GND
7	+3V
8	GND
9	SMB_CLK_MAIN
10	SMB_DATA_MAIN
11	C_ESPI_IO0
12	C_ESPI_IO1
13	C_ESPI_IO2
14	C_ESPI_IO3
15	GND
16	+3VSB
17	N/A
18	N/A
19	C_ESPI_ALERT#
20	GND

### MIPI Header

(22-pin MIPI)

(see p. 50, No. 15)

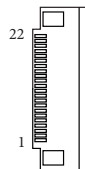

Pin	Signal Name
1	+3V
2	I2C0_SDA
3	I2C0_SCL
4	GND
5	N/A
6	N/A
7	GND
8	CSI_E_D3_DP
9	CSI_E_D3_DN
10	GND
11	CSI_E_D2_DP
12	CSI_E_D2_DN
13	GND
14	CSI_E_CK_DP
15	CSI_E_CK_DN
16	GND
17	CSI_E_D1_DP
18	CSI_E_D1_DN
19	GND
20	CSI_E_D0_DP
21	CSI_E_D0_DN
22	GND

**PCIe Connectors**

(20-pin PCIe1)

(see p. 50, No. 19)



Pin	Signal Name
1	+12V
2	+12V
3	PLT_RST#
4	GND
5	CLKP
6	CLKN
7	GND
8	PCIEX_TXP
9	PCIEX_TXN
10	GND
11	PCIEX_RXP
12	PCIEX_RXN
13	GND
14	CLKREQ#
15	GND
16	+12V
17	+12V
18	+12V
19	+12V
20	+12V

**Power Connectors (12V/GND)**

(4-pin DC\_OUT1)

(see p. 50, No. 21)



Pin	Signal Name
1	+12VSB
2	GND
3	GND
4	+12VSB

**Battery Connector**

(2-pin BAT1)

(see p. 50, No. 22)



Pin	Signal Name
1	+BAT
2	GND

**Backside:****Fan Connector**

(4-pin FAN1)

(see p. 51, No. 30)



Pin	Signal Name
1	GND
2	+5V
3	FAN_SPEED
4	FAN_SPEED_CONTROL

## 4.4 Expansion Slots (M.2 Sockets)

There are three M.2 sockets on the motherboard.

### M.2 Key-M Socket (M2\_M1)

(see p. 50, No. 16)

### M.2 Key M Socket (2280)(PCIe Gen4)

Pin	Signal Name	Signal Name	Pin
1	GND	+3.3V	2
3	GND	+3.3V	4
5	PERR3	NA	6
7	PERP3	NA	8
9	GND	SATA_LED	10
11	PEIn3	+3.3V	12
13	PEIp3	+3.3V	14
15	GND	+3.3V	16
17	PERR2	+3.3V	18
19	PERP2	NA	20
21	GND	NA	22
23	PEIn2	NA	24
25	PEIp2	NA	26
27	GND	NA	28
29	PERR1	NA	30
31	PERP1	NA	32
33	GND	NA	34
35	PEIn1	NA	36
37	PEIp1	NA	38
39	GND	SMB_CLK	40
41	PERR0	SMB_DATA	42
43	PERP0	NA	44
45	GND	NA	46
47	PEIn0	NA	48
49	PEIp0	PERST#	50
51	GND	CLKREQ#	52
53	PEFCKn	NA	54
55	PEFCKp	NA	56
57	GND	NA	58
67	NA	NA	68
69	PEDET	+3.3V	70
71	GND	+3.3V	72
73	GND	+3.3V	74
75	GND		

### M.2 Key-E Socket (M2\_E1):

(see p. 50, No.17)

### M.2 Key E Socket (2230/2260)(CNVio/CNVio2/PCIe Gen3/USB 2.0 mode)

- Supports Wifi/BT module

Pin	Signal Name	Signal Name	Pin
1	GND	+3.3V	2
3	USB_D+	+3.3V	4
5	USB_D-	NA	6
7	GND	NA	8
9	CNV_WGR_D1-	CNV_RF_RESET	10
11	CNV_WGR_D1+	NA	12
13	GND	MODEM_CLKREQ	14
15	CNV_WGR_D0-	NA	16
17	CNV_WGR_D0+	GND	18
19	GND	NA	20
21	CNV_WGR_CLK-	CNV_BRI_RSP	22
23	CNV_WGR_CLK+		
		CNV_BGI_DT	32
33	GND	CNV_RGI_RSP	34
35	PEIp	CNV_BRI_DT	36
37	PEIn	NA	38
39	GND	NA	40
41	PERP	NA	42
43	PERR	NA	44
45	GND	NA	46
47	PEFCKp	NA	48
49	PEFCKn	SUSCLK	50
51	GND	PERST0	52
53	CLKREQ#	W_DISABLE1#	54
55	NA	W_DISABLE2#	56
57	GND	SMB_DATA	58
59	CNV_WT_D1-	SMB_CLK	60
61	CNV_WT_D1+	NA	62
63	GND	NA	64
65	CNV_WT_D0-	NA	66
67	CNV_WT_D0+	NA	68
69	GND	NA	70
71	CNV_WT_CLK-	+3.3V	72
73	CNV_WT_CLK+	+3.3V	74
75	GND		

### M.2 Key-B Socket (M2\_B1)

(see p. 50, No. 18)

### M.2 Key B Socket (3042/3052)

(PCIe Gen3/USB 3.2 mode)

- Supports 4G LTE/5G module

Pin	Signal Name	Signal Name	Pin
1	NA	+3.3V	2
3	GND	+3.3V	4
5	GND	Full_Card_Power_off	6
7	USB_D+	W_DISABLE	8
9	USB_D-	WWAN_LED	10
11	GND		
		NA	20
21	GND	NA	22
23	NA	NA	24
25	NA	NA	26
27	GND	NA	28
29	USB3_RX-	UIM_RESET	30
31	USB3_RX+	UIM_CLK	32
33	GND	UIM_DATA	34
35	USB3_TX-	UIM_PWR	36
37	USB3_TX+	NA	38
39	GND	NA	40
41	PERR0	NA	42
43	PERP0	NA	44
45	GND	NA	46
47	PEIn0	NA	48
49	PEIp0	PERST#	50
51	GND	CLKREQ#	52
53	PEFCKn	NA	54
55	PEFCKp	NA	56
57	GND	NA	58
59	NA	NA	60
61	NA	NA	62
63	NA	NA	64
65	NA	NA	66
67	NA	NA	68
69	PEDET	+3.3V	70
71	GND	+3.3V	72
73	GND	+3.3V	74
75	NA		

# Chapter 5 UEFI Setup Utility

## 5.1 Introduction

ASRock Industrial UEFI (Unified Extensible Firmware Interface) is a BIOS utility which offers tweak-friendly options in an advanced viewing interface. The UEFI system works with a USB mouse and offers users a faster, sleeker experience.

This BIOS utility can perform the Power-On Self-Test (POST) during system startup, record hardware parameters of the system, load operating system, and so on. The battery on the motherboard supplies the power needed to the CMOS when the system power is turned off, and the values configured in the UEFI utility are kept in the CMOS.

Please note that inadequate BIOS settings may cause system instability, malfunction or boot failure. We strongly recommend that you do not alter the UEFI default configurations or change the settings only with the assistance of a trained service person.

If the system becomes unstable or fails to boot after you change the setting, try to clear the CMOS values and reset the board to default values. See your motherboard manual for instructions.

### 5.1.1 Entering BIOS Setup

You may run the UEFI Setup Utility by pressing <F2> or <Delete> right after you power on the computer; otherwise, the Power-On-Self-Test (POST) will continue with its test routines. If you wish to enter the UEFI Setup Utility after POST, restart the system by pressing <Ctl> + <Alt> + <Delete>, or by pressing the reset button on the system chassis. You may also restart by turning the system off and then back on.

This setup guide explains how to use the UEFI Setup Utility to configure all the supported system. The screenshots in this manual are for reference only. UEFI Settings and options may vary owing to different BIOS release versions or CPU installed. Please refer to the actual BIOS version of the motherboard you purchased for detailed screens, settings and options.

## 5.1.2 UEFI Menu Bar

The top of the screen has a menu bar with the following selections:

<b>Main</b>	For setting system time/date information
<b>Advanced</b>	For advanced system configurations
<b>H/W Monitor</b>	Displays current hardware status
<b>Security</b>	For security settings
<b>Boot</b>	For configuring boot settings and boot priority
<b>Exit</b>	Exit the current screen or the UEFI Setup Utility



*Because the UEFI software is constantly being updated, the following UEFI setup screens and descriptions for reference purpose only, and may vary from the latest BIOS and do not exactly match what you see on your screen.*

### 5.1.3 Navigation Keys

Use <←> key or <→> key to choose among the selections on the menu bar, and use

<↑> key or <↓> key to move the cursor up or down to select items, then press <Enter> to get into the sub screen. You can also use the mouse to click your required item.

Please check the following table for the descriptions of each navigation key.

Navigation Key(s)	Description
+ / -	To change option for the selected items
<Tab>	Switch to next function
<PGUP>	Go to the previous page
<PGDN>	Go to the next page
<HOME>	Go to the top of the screen
<END>	Go to the bottom of the screen
<F1>	To display the General Help Screen
<F7>	Discard changes and exit the SETUP UTILITY
<F9>	Load optimal default values for all the settings
<F10>	Save changes and exit the SETUP UTILITY
<F12>	Print screen
<ESC>	Jump to the Exit Screen or exit the current screen

## 5.2 Main Screen

When you enter the UEFI SETUP UTILITY, the Main screen will appear and display the system overview.

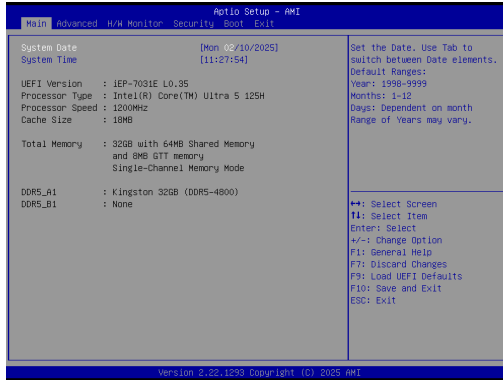

*Because the UEFI software is constantly being updated, the following UEFI setup screens and descriptions are for reference purpose only, and they may not exactly match what you see on your screen. Options may also vary depending on the features of your motherboard.*

## 5.3 Advanced Screen

In this section, you may set the configurations for the following items: CPU Configuration, Chipset Configuration, Storage Configuration, Super IO Configuration, AMT Configuration, ACPI Configuration, USB Configuration, and Trusted Computing.

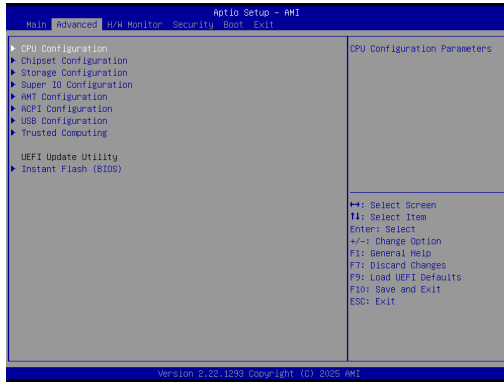

Setting wrong values in this section may cause the system to malfunction.

### Instant Flash (BIOS)

Instant Flash (BIOS) is a UEFI flash utility embedded in Flash ROM. This convenient UEFI update tool allows you to update system UEFI without entering operating systems first like MSDOS or Windows\*. Just launch this tool and save the new UEFI file to your USB flash drive, floppy disk or hard drive, and then you can update your UEFI in only a few clicks without preparing an additional floppy diskette or other complicated flash utility. Please be noted that the USB flash drive or hard drive must use FAT32/16/12 file system. If you execute Instant Flash (BIOS) utility, the utility will show the UEFI files and their respective information. Select the proper UEFI file to update your UEFI, and reboot your system after UEFI update process completes.

## 5.3.1 CPU Configuration

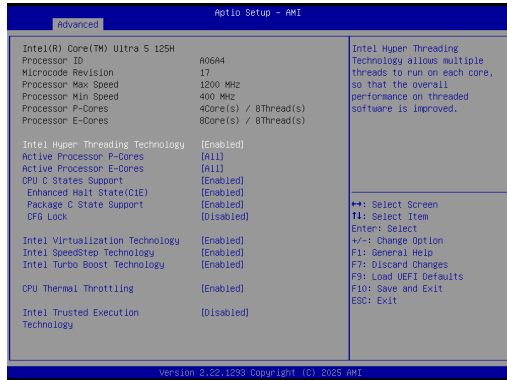

### Intel Hyper Threading Technology

Intel Hyper Threading Technology allows multiple threads to run on each core, so that the overall performance on threaded software is improved.

Configuration options: [Enabled] [Disabled]

### Active Processor P-Cores

This allows you to select the number of cores to enable in each processor package.

### Active Processor E-Cores

This allows you to select the number of E-Cores to enable in each processor package.

NOTE: Number of P-Cores and E-Cores are looked at together. When both are {0,0},

Pcode will enable all cores.

### CPU C States Support

This allows you to enable CPU C States Support for power saving. It is recommended to keep C3, C6 and C7 all enabled for better power saving.

Configuration options: [Enabled] [Disabled]

### Enhanced Halt State (C1E)

The option allows you to enable Enhanced Halt State (C1E) for lower power consumption.

Configuration options: [Enabled] [Disabled]

## Package C State Support

The option allows you to enable CPU, PCIe, Memory, Graphics C State Support for power saving.

## CFG Lock

The option allows you to enable or disable the CFG Lock.

Configuration options: [Enabled] [Disabled]

## Intel Virtualization Technology

When this option is set to [Enabled], a VMM (Virtual Machine Architecture) can utilize the additional hardware capabilities provided by Vanderpool Technology. This option will be hidden if the installed CPU does not support Intel Virtualization Technology.

Configuration options: [Enabled] [Disabled]

## Intel SpeedStep Technology

Intel SpeedStep technology allows processors to switch between multiple frequencies and voltage points for better power saving and heat dissipation. CPU turbo ratio can be fixed when Intel SpeedStep Technology is set to [Disabled] and Intel Turbo Boost Technology is set to [Enabled].

If you install Windows® 10 and want to enable this function, please set this item to [Enabled]. This item will be hidden if the current CPU does not support Intel SpeedStep technology.

Configuration options: [Enabled] [Disabled]



*Please note that enabling this function may reduce CPU voltage and lead to system stability or compatibility issues with some power supplies. Please set this item to [Disabled] if above issues occur.*

## Intel Turbo Boost Technology

Intel Turbo Boost Technology enables the processor to run above its base operating frequency when the operating system requests the highest performance state. The default value is [Enabled].

Configuration options: [Enabled] [Disabled]

---

## CPU Thermal Throttling

CPU Thermal Throttling allows you to enable CPU internal thermal control mechanisms to keep the CPU from overheating.

Configuration options: [Enabled] [Disabled]

## Intel Trusted Execution Technology

This item allows you to enable or disable the Intel Trusted Execution Technology function.

### 5.3.2 Chipset Configuration

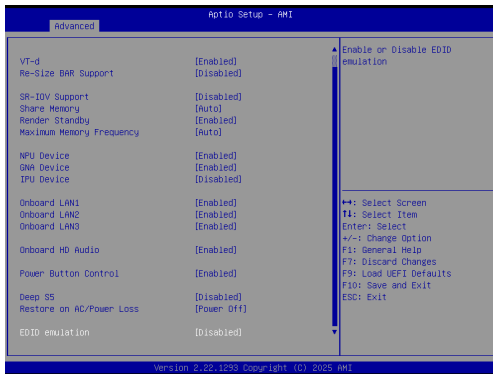
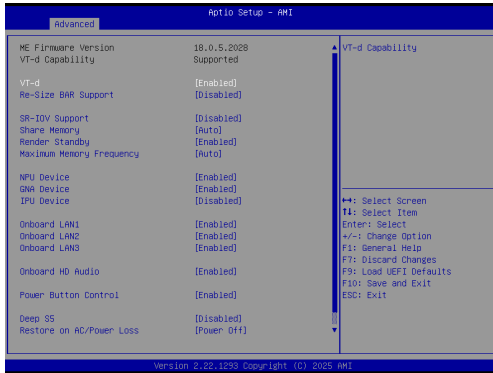

#### VT-d

Intel® Virtualization Technology for Directed I/O helps your virtual machine monitor better utilize hardware by improving application compatibility and reliability, and providing additional levels of manageability, security, isolation, and I/O performance.

Configuration options: [Enabled] [Disabled]

#### Re-Size BAR Support

If system has Resizable BAR capable PCIe Devices, this option enables or disables Resizable BAR Support.

## SR-IOV Support

If system has SR-IOV capable PCIe Devices, this option Enables or Disables Single Root IO Virtualization Support.

Configuration options: [Enabled] [Disabled]

## Share Memory

Share memory allows you to configure the size of memory that is allocated to the integrated graphics processor when the system boots up.

Configuration options: [Auto] [32M] [64M] [128M] [256M] [512M]

Options vary depending on the memory you use on your motherboard.

## Render Standby

Power down the render unit when the GPU is idle for lower power consumption.

## Maximum Memory Frequency

Selections in Mhz.

## NPU Device

This allows you to enable or disable NPU (Neural Processing Unit) Device.

Configuration options: [Enabled] [Disabled]

## GNA Device

This allows you to enable or disable GNA Device.

Configuration options: [Enabled] [Disabled]

## IPU Device

Enable/Disable SA IPU Device. This option will be grayed out when IPU is fused off from silicon.

## Onboard LAN1

This allows you to enable or disable the Onboard LAN1 feature.

## Onboard LAN2

This allows you to enable or disable the Onboard LAN2 feature.

## Onboard LAN3

This allows you to enable or disable the Onboard LAN3 feature.

## Onboard HD Audio

Select [Auto], [Enabled] or [Disabled] for the onboard HD Audio feature. If you select [Auto], the onboard HD Audio will be disabled when PCI Sound Card is plugged.

## Power Button Control

The item enables or disables Power Button Function.

## Deep S5

Mobile platforms support Deep S5 in DC only and desktop platforms support Deep S5 in AC only. The default value is [Disabled].

Configuration options: [Auto] [Disabled]

## Restore on AC/Power Loss

Select the power state after a power failure. If [Power Off] is selected, the power will remain off when the power recovers. If [Power On] is selected, the system will start to boot up when the power recovers.

## EDID emulation

This allows you to enable or disable the EDID emulation feature.

## 5.3.3 Storage Configuration



### VMD Configuration

This item allows you to enable or disable the Intel VMD support function.

### SATA Controller(s)

The option allows you to enable or disable the SATA controllers.

Configuration options: [Enabled] [Disabled]

### SATA Mode Selection

AHCI supports new features that improve performance.

Configuration option: [AHCI]



*AHCI (Advanced Host Controller Interface) supports NCQ and other new features that will improve SATA disk performance but IDE mode does not have these advantages.*

### SATA Aggressive Link Power Management

SATA Aggressive Link Power Management allows SATA devices to enter a low power state during periods of inactivity to save power. It is supported only by AHCI mode.

Configuration options: [Enabled] [Disabled]

## Hard Disk S.M.A.R.T.

S.M.A.R.T stands for Self-Monitoring, Analysis, and Reporting Technology. It is a monitoring system for computer hard disk drives to detect and report on various indicators of reliability.

Configuration options: [Enabled] [Disabled]

## 5.3.4 Super IO Configuration

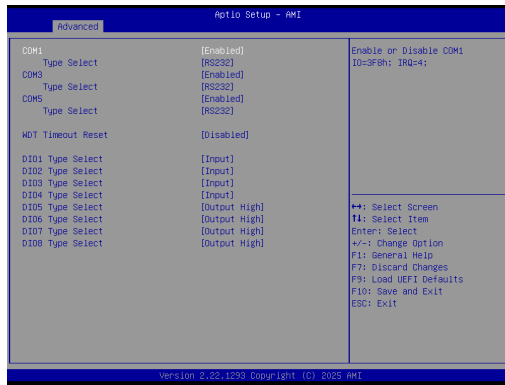

### COM1

Use this to set parameters of COM1.

#### Type Select

Use this to select COM1 port type: [RS232], [RS422] or [RS485].

### COM3

Use this to set parameters of COM3.

#### Type Select

Use this to select COM3 port type: [RS232], [RS422] or [RS485].

### COM5

Use this to set parameters of COM5.

#### Type Select

Use this to select COM4 port type: [RS232], [RS422] or [RS485].

### WDT Timeout Reset

Use this to set the Watch Dog Timer.

#### DIO1 Type Select

Use this to set DIO Type: [Input].

### DIO2 Type Select

Use this to set DIO Type: [Input].

### DIO3 Type Select

Use this to set DIO Type: [Input].

### DIO4 Type Select

Use this to set DIO Type: [Input].

### DIO5 Type Select

Use this to set DIO Type: [Input].

### DIO6 Type Select

Use this to set DIO Type: [Input].

### DIO7 Type Select

Use this to set DIO Type: [Input].

### DIO8 Type Select

Use this to set DIO Type: [Input].

**Pin Location and Corresponding Signal**

DIO	Function
DIO1	GPP_B7
DIO2	GPP_B8
DIO3	GPP_B15
DIO4	GPP_B17
DIO5	GPP_D5
DIO6	GPP_D7
DIO7	GPP_D8
DIO8	GPP_D14

## 5.3.5 AMT Configuration

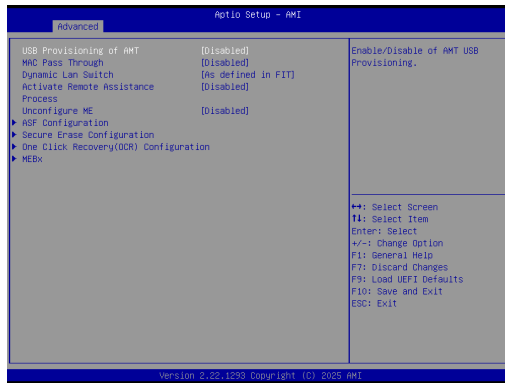

### USB Provisioning of AMT

Use this to enable or disable AMT USB Provisioning. The default is [Disabled].

### MAC Pass Through

The option enables or disables MAC Pass Through function.

### Dynamic Lan Switch

This allows switching AMT support from Integrated LAN to Discrete LAN.

### Activate Remote Assistance Process

Trigger CIRA boot. The default is [Disabled].

### Unconfigure ME

Unconfigure ME without password. The default is [Disabled].

### ASF Configuration

The option allows you to configure Alert Standard Format parameters.

### Secure Erase Configuration

Secure Erase configuration menu.

### One Click Recovery(OCR) Configuration

Configuration setting for One Click Recovery. This allows access for AMT to boot a recovery OS application.

## MEBx

This Formset contains forms for configuring MEBx.

## 5.3.6 ACPI Configuration

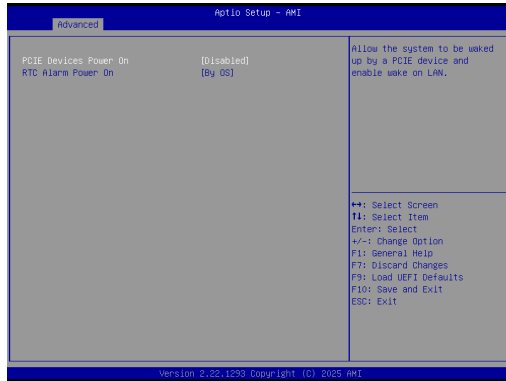

### PCIE Devices Power On

Use this item to enable or disable PCIE devices to turn on the system from the power-soft-off mode.

### RTC Alarm Power On

RTC Alarm Power On allows the system to be waked up by the real time clock alarm. Set it to By OS to let it be handled by your operating system.

Configuration options: [Enabled] [Disabled] [By OS]

### 5.3.7 USB Configuration

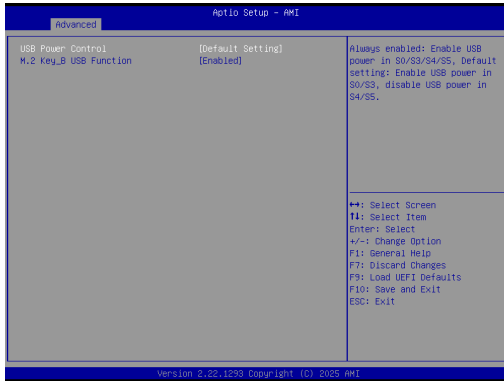

#### USB Power Control

Use this option to control USB power.

#### M.2 Key\_B Function

The item enables or disables M.2 Key\_B USB function.

## 5.3.8 Trusted Computing



### Security Device Support

Security Device Support allows you to enable or disable BIOS support for security device. O.S. will not show Security Device. TCG EFI protocol and INT1A interface will not be available.

Configuration options: [Enabled] [Disabled]

### Active PCR banks

This item displays active PCR Banks.

### Available PCR Banks

This item displays available PCR Banks.

### SHA256 PCR Bank

SHA256 PCR Bank allows you to enable or disable SHA256 PCR Bank.

Configuration options: [Enabled] [Disabled]

### Pending Operation

Pending Operation allows you to schedule an Operation for the Security Device.

NOTE: Your computer will reboot during restart in order to change State of the Device.

Configuration options: [None] [TPM Clear]

### Platform Hierarchy

This item allows you to enable or disable Platform Hierarchy.

Configuration options: [Enabled] [Disabled]

## Storage Hierarchy

This item allows you to enable or disable Storage Hierarchy.

Configuration options: [Enabled] [Disabled]

## Endorsement Hierarchy

This item allows you to enable or disable Endorsement Hierarchy.

Configuration options: [Enabled] [Disabled]

## Physical Presence Spec Version

Select this item to tell OS to support PPI spec version 1.2 or 1.3. Please note that some HCK tests might not support version 1.3.

Configuration options: [1.2] [1.3]

## TPM 2.0 InterfaceType

This item allows you to view the Communication Interface to TPM 2.0 Device: CRB or TIS.

## PH Randomization

The item enables or disables Platform Hierarchy randomization.

## Device Select

This item allows you to select the TPM device to be supported.

[TPM 1.2] restricts support to TPM 1.2 devices.

[TPM 2.0] restricts support to TPM 2.0 devices.

[Auto] supports both TPM 1.2 and TPM 2.0 devices with the default set to TPM 2.0 devices. If TPM 2.0 devices are not found, TPM 1.2 devices will be enumerated.

## Onboard TPM

The option enables or disables Intel PTT in ME. Disable this option to use discrete TPM Module.

## 5.4 Hardware Health Event Monitoring Screen

In this section, it allows you to monitor the status of the hardware on your system, including the parameters of the CPU temperature, motherboard temperature, and the critical voltage.

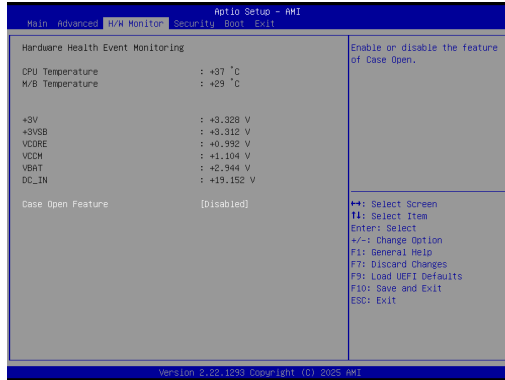

### Case Open Feature

This item allows you to enable or disable case open detection feature. The default is value [Disabled].

### Clear Status

This option appears only when the case open has been detected. Use this option to keep or clear the record of previous chassis intrusion status.

## 5.5 Security Screen

In this section, you may set, change or clear the supervisor/user password for the system.

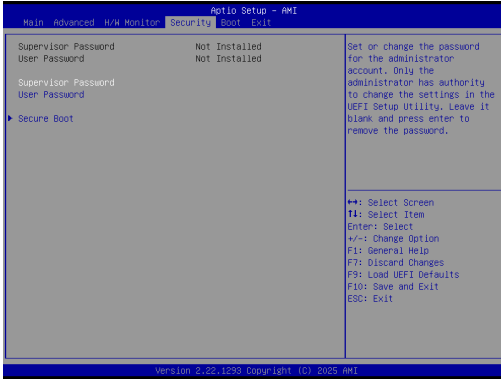

### Supervisor Password

Set or change the password for the administrator account. Only the administrator has the authority to change the settings in the UEFI Setup Utility. Leave it blank and press enter to remove the password.

### User Password

Set or change the password for the user account. Users are unable to change the settings in the UEFI Setup Utility. Leave it blank and press enter to remove the password.

### Secure Boot

Press [Enter] to configure the Secure Boot Settings. The feature protects the system from unauthorized access and malwares during POST. Secure Boot is supported on Window 8 / Ubuntu 12.04 / Fedora 19 and later.

## 5.6 Boot Screen

In this section, it will display the available devices on your system for you to configure the boot settings and the boot priority.

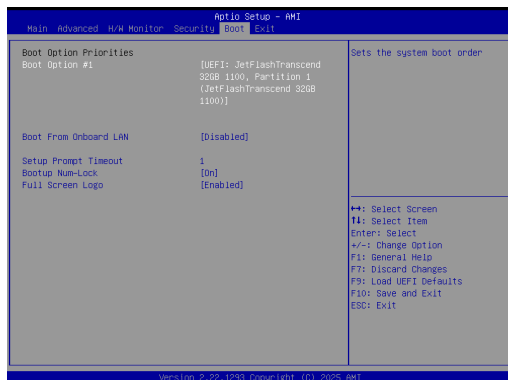

### Boot From Onboard LAN

The item allows the system to be woke up by the onboard LAN.

Configuration options: [Enabled] [Disabled]

### Setup Prompt Timeout

The item allows you to configure the number of seconds to wait for the UEFI setup utility. 65535(0XFFFF) means indefinite waiting.

Configuration options: [1] - [65535]

### Bootup Num-Lock

The item allows you to select whether Num Lock should be turned on or off when the system boots up.

Configuration options: [On] [Off]

### Full Screen Logo

[Enabled] Select this item to display the boot logo.

[Disabled] Select this item to show normal POST messages.

## 5.7 Exit Screen



### Save Changes and Exit

When you select this option, the following message “Save configuration changes and exit setup?” will pop out. Select [Yes] to save the changes and exit the UEFI SETUP UTILITY.

### Discard Changes and Exit

When you select this option, the following message “Discard changes and exit setup?” will pop out. Select [Yes] to exit the UEFI SETUP UTILITY without saving any changes.

### Discard Changes

When you select this option, the following message “Discard changes?” will pop out. Select [Yes] to discard all the changes.

### Load UEFI Defaults

The item allows you to load UEFI default values for all options. The F9 key can be used for this operation.

### Launch EFI Shell from filesystem device

The item allows you to copy shellx64.efi to the root directory to launch EFI Shell.